

Dual Safety Shutoff Valves DMV-D/6, DMV-DLE/6

DUNGS®



Two normally closed safety shutoff valves in one housing; each with the following approvals.

UL Recognized

- UL 429
- File # MH16727

CSA Certified

- ANSI Z21.21 • CGA 6.5
- C/I Automatic Valves
- File # 157406-2500000284

FM Approved

- Class 7411
- File # J.I.1Z6A0.AF

EU Gas Appliance Directive

- EN161
- CE-0087AU30

US, Canadian and EU Models

- DMV-D 701/6, 702/6, 703/6
- DMV-DLE 701/6, 702/6, 703/6
- 1/2 in. NPT - 2 in. NPT
- Rp1/2 - Rp2



DUNGS is an ISO 9001 manufacturing facility.

Description

The DUNGS Dual Multi-Valve (DMV) combines two safety shutoff valves in one compact housing, which can be wired independently or in parallel.

Valve 1 (V1) of the DMV-D and DMV-DLE series is fast opening and fast closing. Valve 2 (V2) of the DMV-D is fast opening, while V2 of the DMV-DLE is slow-opening for smoother light-off. Max. flow adjustment on V2 provides variable main flow on both models.

Internal profiles and compact design optimize flow and provide a low pressure drop. Three body styles reduce inventory.

Directly mounting the following DUNGS accessories creates a compact valve train without additional piping:

- Pressure regulator
- High and low gas pressure switches
- Valve proving system
- Vent line adapter

Application

The DUNGS DMV is recommended for industrial and commercial heating applications that require two safety shutoff valves. The DMV Dual Multi-Valve is suitable for natural gas, propane, butane, air and other inert gases.

DMV-D.../6 Two normally closed safety shutoff valves in one housing. V1 and V2 are fast opening, fast closing. Adjustable max flow with V2.

DMV-DLE.../6 Two normally closed safety shutoff valves in one housing. V1 fast opening, fast closing. V2 is slow opening, fast closing. Adjustable max flow and Adjustable initial lift with V2.

Specifications

Body sizes pipe size / thread	DMV 701 1/2" - 1" NPT or Rp	DMV 702 1" - 2" NPT or Rp	DMV 703 1" - 2" NPT or Rp
Max. operating pressure	7 PSI (500 mbar) UL, FM, CE (Class A)		5 PSI (360 mbar) CSA
Max. body pressure	15 PSI (1000 mbar)		
Max. close-off pressure	7 PSI (500 mbar) UL, FM, CE (Class A)		5 PSI (360 mbar) CSA
Electrical ratings (+10% / -15%)	110 - 120 VAC/50 - 60 Hz 24 VAC/ 50 - 60 Hz	220 - 240 VAC/50 - 60 Hz 24 VDC	
Power ratings	DMV 701: 45 VA	DMV 702: 65 VA	DMV 703: 90 VA
	Ratings shown are total power consumption for both valves inclusive. Inrush and full load current have the same VA rating.		
Enclosure rating	NEMA 1		
Electrical connection	DIN-connector with 1/2" NPT conduit adapter		
Operating time	100 % duty cycle		
Closing time	< 1 s		
Opening time (to max. flow)	DMV-D.../6 DMV-DLE.../6	V1 & V2 < 1 s V1 < 1 s; V2 Adjustable to approx. 10 to 20 s at 70 °F	
Initial lift adjustment	Adjustable on V2	DLE only; 0 to 70 % of total flow; 0 to 25% of stroke	
Max. flow adjustment	Adjustable on V2	<10 to 100 % of total flow; <10 to 100% of stroke	
Materials in contact with gas	Housing: Sealings on valve seats:	Aluminium, Steel NBR-based rubber	
Ambient temperature rating	-40 °F to +150 °F (-40 °C to +65 °C)		
Installation position	Safety valve upright vertical to horizontal		
Test ports / Pressure switch mounting ports	G 1/8 ISO 228 ports available on both sides. Each side has one port upstream V1, one between V1 and V2, one downstream V2, and one on each flange.		
Gas filter (optional)	Replaceable integral gas filter (50 micron) in inlet of DMV or Pre-Mount Filter Block for DMV 702 and 703. (Cannot be used with FRI directly mounted to the DMV.)		
Gas strainer (standard)	Installed in the housing upstream V1 (23 mesh)		
Position indication (order separately)	CPI 400 with indication lamps and SPDT interlock switch or Visual indicator (VI)		
Valve proving system	Requires VPS 504; mounts directly to either side of DMV.		

DMV dual safety shutoff valve modular system

Optional mounting system shown,
other configurations possible

DMV dual safety shutoff valve with upstream FRI pressure regulator

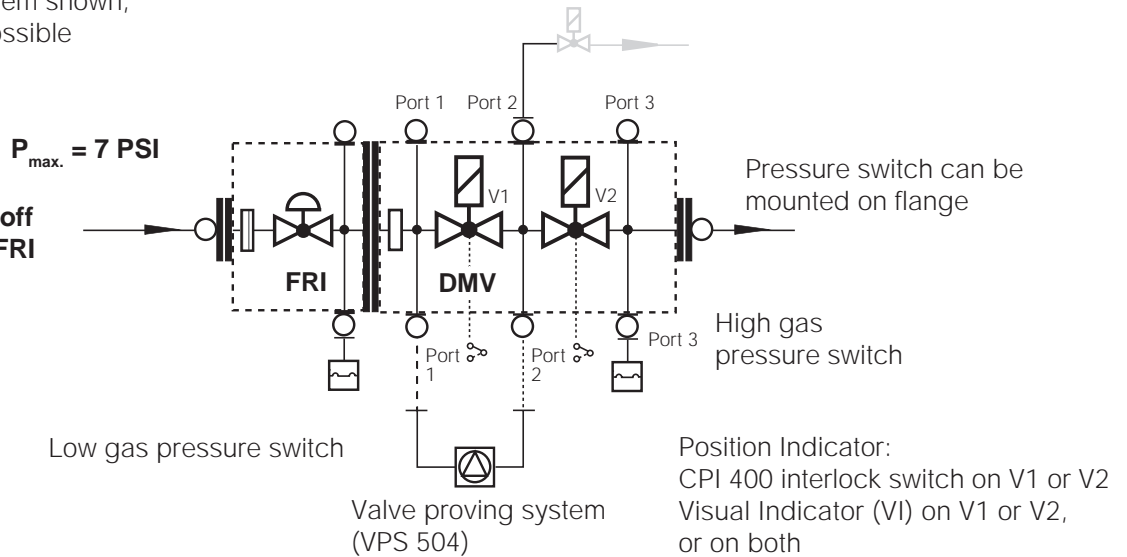

DMV dual safety shutoff valve with downstream FRI pressure regulator

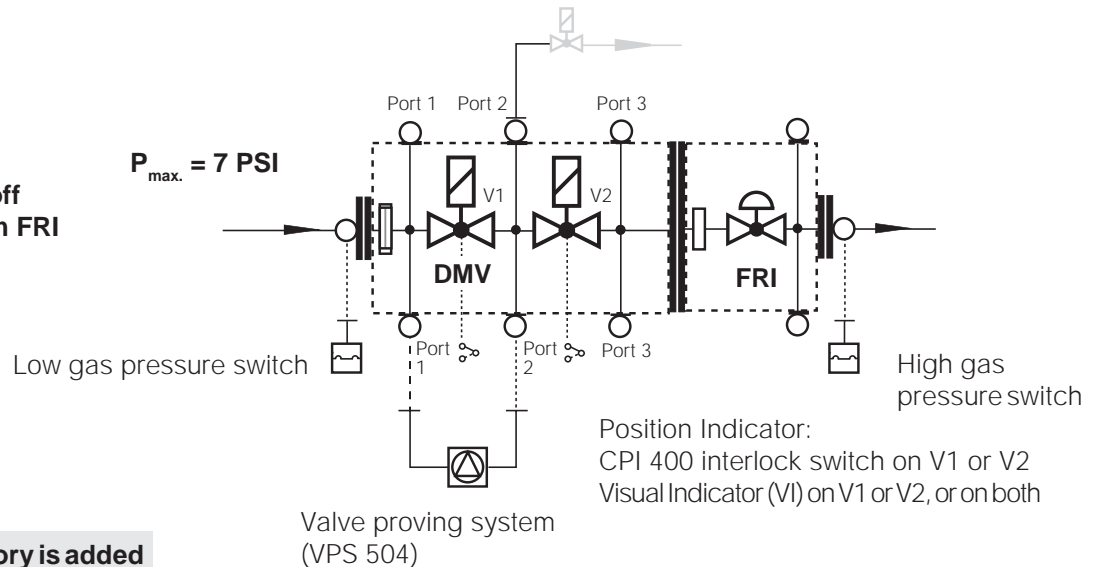

When an accessory is added to the DMV, it may not be possible to mount other devices.

FRI Gas pressure regulator

Mounting the FRI series gas pressure regulator directly to the DMV dual safety shutoff valve is possible with a mounting kit.

The FRI pressure regulator can be installed upstream or downstream of the DMV dual safety shutoff valve depending on application requirements.

FRI mounting kit for DMV

FRI 705 - 707/6 to DMV 701/6
Order No. 219 967
(Previously FRI 505-507/6)

FRI 710-712/6 to DMV 702/6 + 703/6
Order No. 219 968
(Previously FRI 505-507/6)

Additional Accessories

VPS 504

Valve proving system (approved by some authorities having jurisdiction in lieu of vent valve and "proof of closure" e.g. FM, IRI).

Integral gas filter (optional)

50 micron gas filter

Pre-Mount Filter (optional)

50 micron gas filter

GAO/GMH/GML A2 pressure switch

Position indication

CPI 400 with indication lamps and SPDT interlock switch, or Visual indicator (VI)

DMK butterfly control valve

Mounts directly downstream of DMV to modulate gas flow. Requires actuator. Use DMA actuator with DMK butterfly valve.

DMV D(LE) 7xx/6 VL (with vent line adapter)

Factory installed vent line adapter which integrates a vent line connection with the DMV series.

Adapters

- 1/4" NPT adapter (D225047)
- 1/2" NPT Pilot gas adapter; Check flow requirements. (D225043)
- G 1/8" Test nipple (D219008)
- Port 3 Pressure switch mounting adapter (D214975)

Dimensions inch (mm)

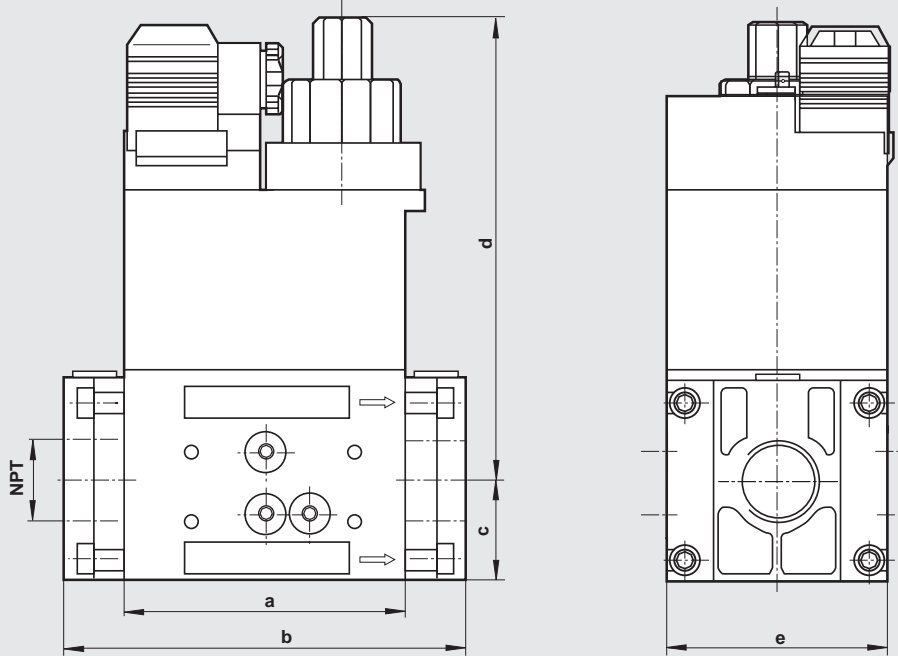

Type	110-120 VAC 50-60 Hz Order No.	220-230 VAC 50-60 Hz Order No.	24 VDC Order No.	24 VAC 50-60 Hz Order No.	Power** [VA]	Dimensions [inch] Dimensions [mm]					Weight [lbs] [kg]
						a	b	c*	d	e	
DMV-D 701/6	D224 842	D228 745	D228 220	D226 990	45	3.7	5.6	1.4	5.3	2.9	4.6
						93	141	35	134	73	2.1
DMV-D 702/6	D224 843	D228 746	D228 221	D226 991	65	4.9	6.9	1.8	5.9	3.9	10.1
						124	174	45	150	101	4.6
DMV-D 703/6	D224 844	D228 747	D228 222	D226 992	90	4.9	7.9	1.8	7.5	3.9	12.1
						124	201	45	190	101	5.6
DMV-DLE 701/6	D224 845	D228 748	D228 223	D226 993	45	3.7	5.6	1.4	5.9	2.9	4.8
						93	141	35	160	73	2.2
DMV-DLE 702/6	D224 846	D228 749	D228 224	D226 994	65	4.9	6.9	1.8	6.7	3.9	10.3
						124	174	45	197	101	4.7
DMV-DLE 703/6	D224 847	D228 750	D228 225	D226 995	90	4.9	7.9	1.8	8.6	3.9	12.3
						124	201	45	218	101	5.7

* When using with the vent line adapter assembly, add 1.65" to dimension c. (see vent line info sheet or call KDI to order)

** Inrush current and full load current have the same VA rating.

Valve	Flange	NPT	Rp	DIN-Connector	
DMV-701/6	1/2"	D222 371	D222 341	CPI 400	D210 319
DMV-701/6	3/4"	D222 368	D222 342	Visual indicator	D224 253
DMV-701/6	1"	D221 999	D222 001		46000-6
DMV-702/6 & 703/6	1"	D222 369	D222 343		
DMV-702/6 & 703/6	1 1/4"	D222 370	D222 344		
DMV-702/6 & 703/6	1 1/2"	D222 003	D221 884		
DMV-702/6 & 703/6	2"	D221 997	D221 926		

 **Please order flanges, position indicators and gas filters separately**

Pre-Mount Filter		Pre-Mount replacement filter		Integral replacement filter (50 micron)	
DMV-701/6	not available	DMV-701/6	not available	DMV-701/6	D214 276
DMV-702/6	D226 342	DMV-702/6	D226 997	DMV-702/6	D214 525
DMV-703/6	D226 342	DMV-703/6	D226 997	DMV-703/6	D214 525

DMV-D(LE).../6
sectional drawing

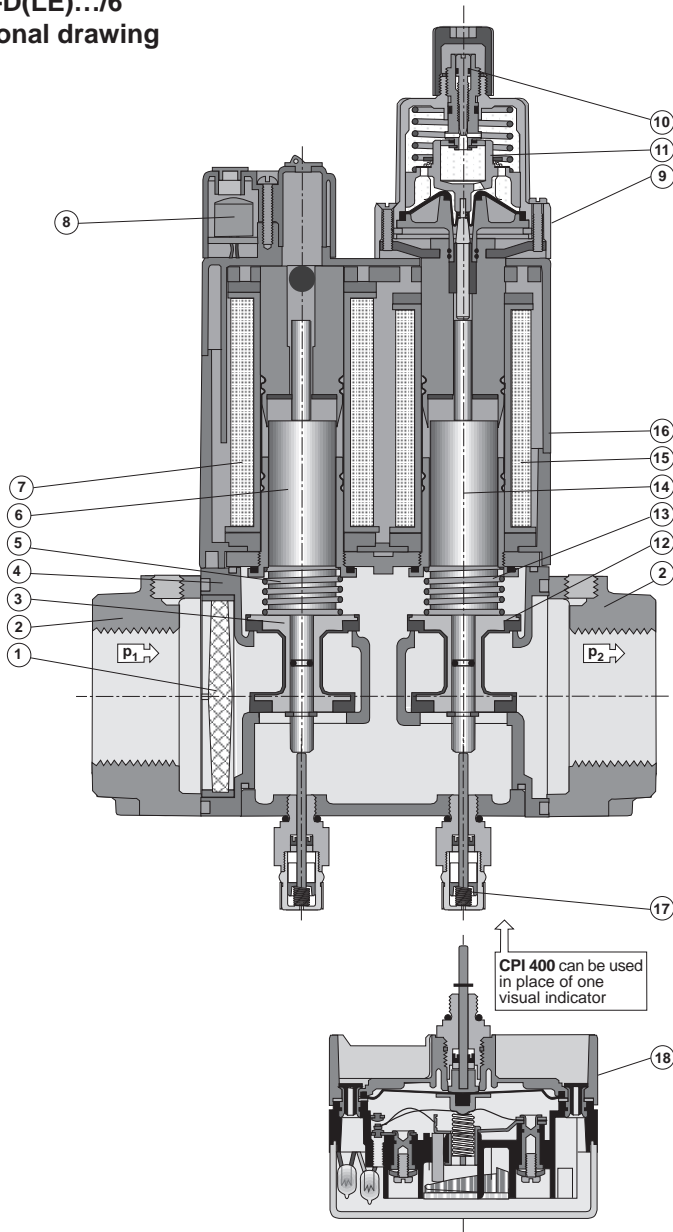

- 1 Strainer
- 2 Flange
- 3 Valve V1
- 4 Housing
- 5 Closing spring V1
- 6 Plunger V1
- 7 Solenoid V1
- 8 Electrical connection
- 9 Max flow adjustment
- 10 Initial lift adjustment (DMV-DLE)
- 11 Hydraulic brake (DMV-DLE)
- 12 Valve V2
- 13 Closing spring V2
- 14 Plunger V2
- 15 Solenoid V2
- 16 Solenoid housing
- 17 Visual indicator (VI)
- 18 CPI 400 interlock switch

$$\dot{V}_{\text{gas used}} = \dot{V}_{\text{Natural Gas}} \times f$$

f = correction factor to determine flow through valves with other gases.

$$f = \sqrt{\frac{\text{Spec. gravity of Natural Gas}}{\text{Spec. gravity of gas used}}}$$

Type of gas	Density [kg/m ³]	sg	f
Natural gas	0.81	0.65	1.00
Butane	2.39	1.95	0.58
Propane	1.86	1.50	0.66
Air	1.24	1.00	0.80

Flow (CFH) of natural gas, s.g. 0.65 at 60 °F with 1 in. W.C. pressure drop

	1/2 "	3/4 "	1 "	1-1/4 "	1-1/2 "	2 "
DMV 701	345	429	457	–	–	–
DMV 702	–	–	1065	1277	1368	1430
DMV 703	–	–	1230	1532	1698	1795

Dual Safety Shutoff Valves
DMV-D/6, DMV-DLE/6



Flow diagram

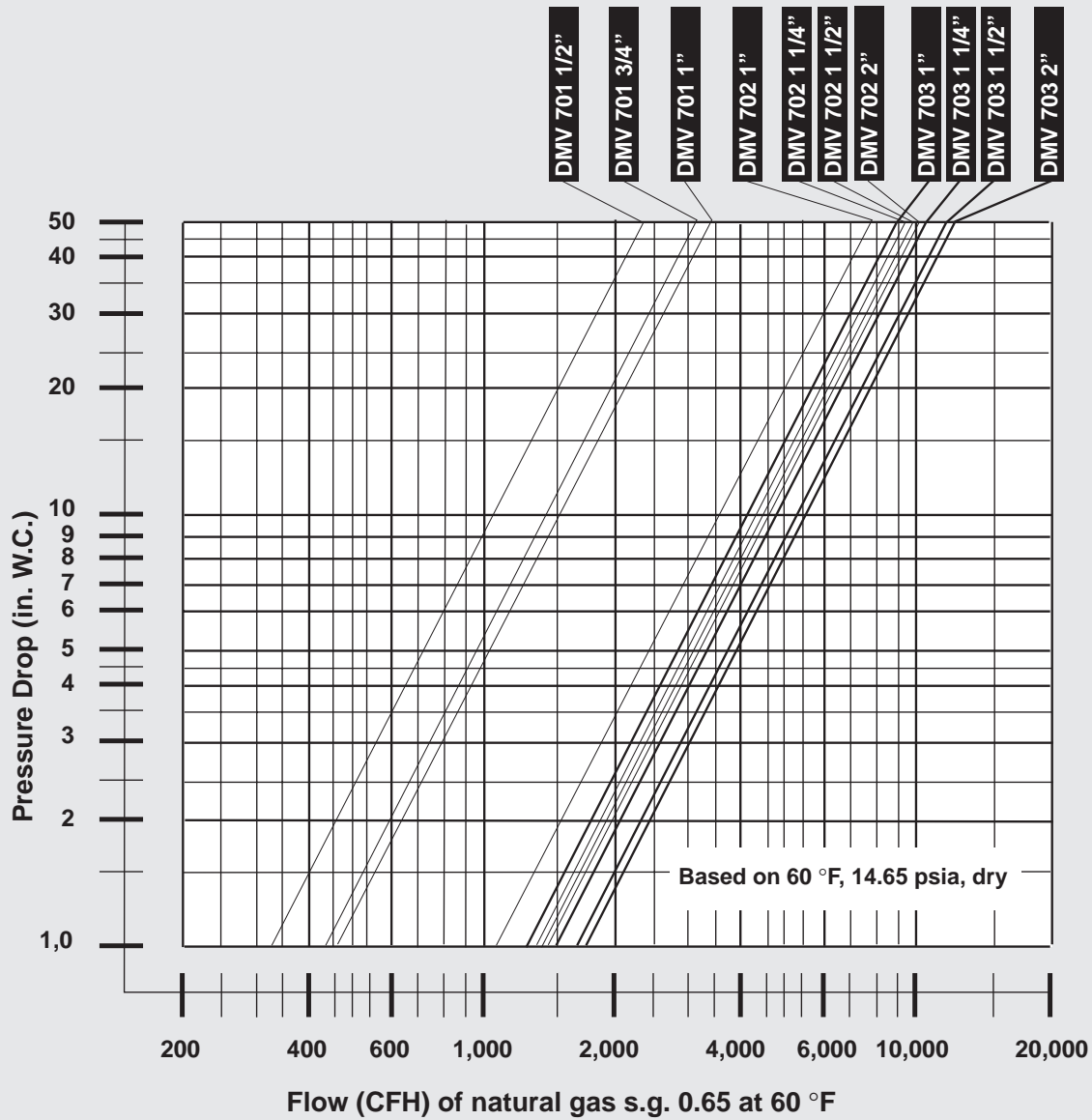

We reserve the right to make any changes in the interest of technical progress.



REG. NO 14 313

Represented By:
Power Equipment Company
2011 Williamsburg Road
Richmond, VA 23231
Tel: 804-236-3800 Fax: 804-236-3882
www.peconet.com