

ML6284 Non-Spring Return Direct Coupled Damper Actuator

PRODUCT DATA



APPLICATION

The ML6284 Non-Spring Return Direct Coupled Damper Actuator provides single pole double through (spdt) floating control of dampers in heating, ventilation, and air conditioning (HVAC) applications. The actuator has an internal, electrically isolated feedback potentiometer that can be used to provide indication of the motor output hub position or control a slave Series 90 actuator.

FEATURES

- Mounts directly on 3/8 in. to 5/8 in. (10 to 17 mm) round and square and 3/4 in. (19 mm) round damper shafts by using the appropriate insert. Most models are shipped with 1/2 in. insert.
- Provides 150 lb-in. (17 N•m) running torque.
- Magnetic coupling eliminates the need for mechanical stops or limit switch adjustments by limiting stall torque to 250 lb-in. (28.3 N•m) maximum.
- 95° stroke provides necessary compression of rubber/neoprene gaskets commonly used on 90° low leakage dampers.
- Manual clutch allows for manual adjustment.
- 92 second synchronous timing can eliminate need for feedback position indication in closed-loop temperature control applications.
- Removable splined output hub permits premounting of hub on damper shaft, providing installation flexibility.
- Designed for both single-point and three-point mounting, to allow installation flexibility.
- Available with or without a time-out feature. Models without the time-out feature are designed to be used with intelligent building management system and/or controller.
- Standard models have two 8 mm by 12 mm long set screws for securing the damper shaft. Actuator models available for various shaft sizes that allow damper shaft to operate centered inside the output hub.

Contents

Application	1
Features	1
Specifications	2
Ordering Information	2
Installation	4
Operation	6
Checkout	8
Troubleshooting	8



SPECIFICATIONS

Models:

- ML6284: Non-Spring Return Direct Coupled Damper Actuators.
- ML6284A: High Torque (150 lb-in.) Direct Coupled Damper Actuator without auxiliary switches or time-out function.
- ML6284C: High Torque (150 lb-in.) Direct Coupled Damper Actuator with two low voltage rated auxiliary switches and without time-out function.
- ML6284D: High Torque (150 lb-in.) Direct Coupled Damper Actuator without auxiliary switches and with time-out function.
- ML6284F: High Torque (150 lb-in.) Direct Coupled Damper Actuator with two low voltage auxiliary switches and with time-out function.

Electrical Ratings:

- Power Input: 24 Vac \pm 20%, 50/60 Hz.
- Power Consumption:
 - ML6284A-C: 5 VA maximum at 24 Vac.
 - ML6284D,F: 6 VA maximum at 24 Vac.
- Auxiliary Switch Ratings: 24 Vac, 3 AFL, 18 ALR, 1A Pilot Duty.

Feedback Resistor:

500 ohm linear potentiometer.

Cable Ratings:

- Control: Standard models include nonplenum UL/CSA rated, 30V, 60°C, 20 gauge cable.
- Auxiliary Switch: UL/CSA rated 300V 90°C, 18 gauge.
- Controller Type: Floating, spdt.

Torque Ratings at Rated Voltages:

- Lift and Hold Minimum: 150 lb-in. (17 N•m).
- Breakaway Minimum: 150 lb-in. (17 N•m).
- Stall Minimum: 150 lb-in. (17 N•m).
- Stall Maximum: 250 lb-in. (28.3 N•m).

Torque Deratings at 24 Vac \pm 20%:

- 150 lb-in. from -20°F to +95°F (-29°C to +35°C).
- 133 lb-in. from 95°F to 140°F (35°C to 60°C).
- 150 lb-in. from -40°F to -20°F (-40°C to -29°C) (at 24 Vac +20% only).

Actuator Stroke:

95° Nominal \pm 3°, mechanically limited.

Actuator Timing at 90° Stroke:

- 92 \pm 2 seconds synchronous at 60 Hz from -4°F to 140°F (-20°C to +60°C).
- 110 \pm 2 seconds synchronous at 50 Hz from -4°F to 140°F (-20°C to +60°C).
- Non synchronous below -4°F (-16°C).

Ambient Temperature Range:

-30°F to +140°F (-35°C to +60°C).

Storage Temperature:

-30°F to 150°F (-35°C to 65°C).

Humidity:

5 to 95 percent relative humidity, noncondensing.

Mounting:

- Mounts directly on horizontal 3/8 in. to 5/8 in. (12 to 17 mm) round or square or 3/4 in. (19 mm) round damper shaft.
- Minimum shaft length required:
 - 2.5 in. (64 mm) when the shaft attachment is made on the side of the actuator opposite the duct;
 - 0.65 in. (16 mm) when the hub is mounted on the shaft before the actuator is installed.
- Most actuators are shipped with specifically sized hubs. Some models contain an assembly with assorted hub inserts.
- Mounting bracket is included with most models.

Dimensions:

See Fig. 1.

Device Weight:

3.0 lb (1.36 kg).

Noise Rating:

Driving Only: 45 dBA maximum at 1.0m.

Position Indicator:

Mounted on actuator hub.

Actuator Design Life:

Full Stroke Cycles:100,000.

Repositions:

2,000,000 minimum.

ORDERING INFORMATION

When purchasing replacement and modernization products from your TRADELINE® wholesaler or distributor, refer to the TRADELINE® Catalog or price sheets for complete ordering number, or specify:

1. Model number.
2. Application.

If you have additional questions, need further information, or would like to comment on our products or services, please write or phone:

1. Your local Honeywell Home and Building Control Sales Office (check white pages of your phone directory).
2. Home and Building Control Customer Logistics
Honeywell Inc., 1885 Douglas Drive North,
Minneapolis, Minnesota 55422-4386 (612) 951-1000

In Canada—Honeywell Limited/Limitée, 155 Gordon Baker Road, North York, Ontario M2H 2C9. International Sales and Service offices in all principal cities of the world.

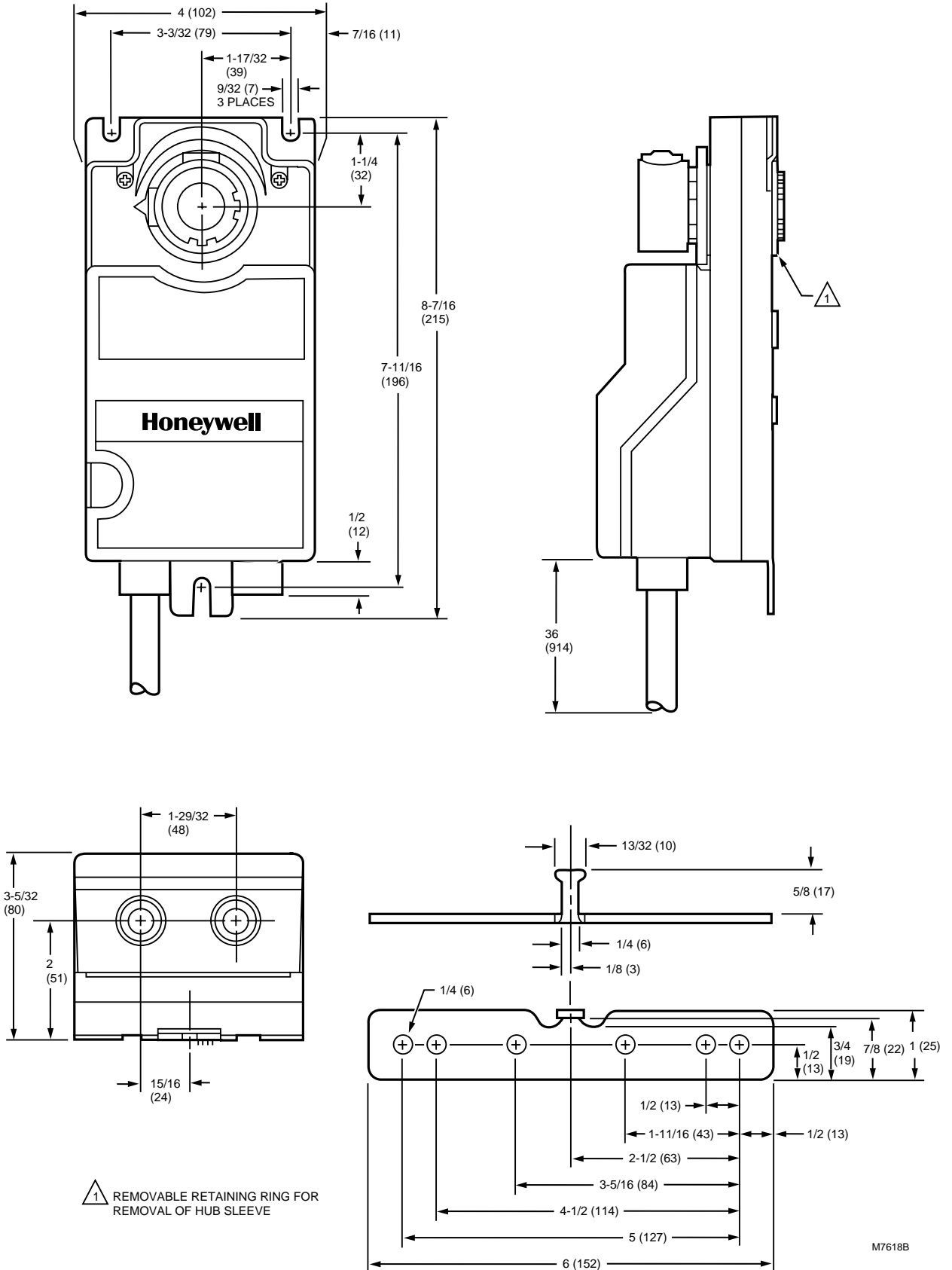

Fig. 1. Approximate dimensions of ML6284 Non-Spring Return Direct Coupled Damper Actuator and mounting bracket in in. (mm).

Approvals:

- UL94-5V Enclosure: Plenum rating.
- UL873: Low voltage auxiliary switches.
- UL Listed: File number E4436, Guide number XAPX.
- CSA Listed: File number LR95329-17.

Environmental Protection Ratings:

NEMA1 standard with damper shaft in horizontal position.

Accessories:

- 205617 Hub Insert, 3/4 in. round.
- 205753 Hub Insert, 3/8 in.
- 205758 Hub Insert, 5/8 in.
- 205820A 3-Point Mounting Kit.
- 205685 Crank-Arm Accessory.
- 205850B End Stop Kit.

INSTALLATION

When Installing this Product...

1. Read instructions carefully. Failure to follow them could damage the product or cause a hazardous condition.
2. Check ratings and description given in the specifications to make sure the product is suitable for your application.
3. Installer must be a trained, experienced service technician.
4. After installation is complete, check out product operation as provided in these instructions.

CAUTION



1. Disconnect power before installation to prevent electrical shock or equipment damage.
2. Never turn motor output hub by hand or wrench.
3. Do not install actuator in areas with acid fumes or other deteriorating vapors that might attack the metal parts of the actuator.
4. Do not install actuator in areas with escaping gas or other explosive vapors that could be ignited by a spark from the actuator or attached accessories.

Location

Install the actuator in any location free from acid fumes or other deteriorating vapors that might attack the metal parts of the actuator. Make sure the location is not subject to escaping gas or other explosive vapors that could accidentally be ignited by a spark from the actuator or its attached parts.

Install the actuator in a location that allows enough clearance for mounting accessories and for servicing.

Mounting

The ML6284 Non-Spring Return Direct Coupled Damper Actuator is designed to operate a damper by driving the damper shaft either cw  or ccw  depending on damper design. All actuators are shipped in the fully closed position.

The ML6284 Non-Spring Return Direct Coupled Damper Actuator is designed with removable hub inserts to accommodate specific damper shaft sizes. Proper sleeve selection is necessary when three-point mounting is used to avoid excessive strain on the output gear. Most ML6284 Actuators are shipped with a 1/2 in. hub insert. For field use,

two hub insert sizes are available. See the Accessories listing in the Specifications section. Shaft sizes are stamped on the inserts.

The ML6284 Non-Spring Return Direct Coupled Damper Actuator is designed for single-point mounting when using a mounting bracket. Single-point mounting is typically used when the actuator is mounted on the damper shaft.

The ML6284 Non-Spring Return Direct Coupled Damper Actuator can be mounted directly on the damper shaft with the actuator in any position.

A mounting bracket (see Fig. 1) is provided with some models to aid in installing the actuator. The bracket can be bent to any shape to allow the bracket tab to be centered in the actuator slot.

CAUTION

The mounting bracket must not bind or clamp the actuator to the duct. The mounting bracket only prevents the actuator housing from rotating.

The ML6284 Direct Coupled Damper Actuator has a reversible output hub. The hub is factory mounted on the top of the actuator gear housing. When attaching to damper shafts less than 2.5 in. (64 mm) long, or for ease of mounting, the output hub may be mounted to the back of the actuator gear housing. See Fig. 3. Be careful when removing the retaining ring which secures the output hub sleeve to the actuator housing. Use a flatheaded screwdriver to pry the retaining ring loose.

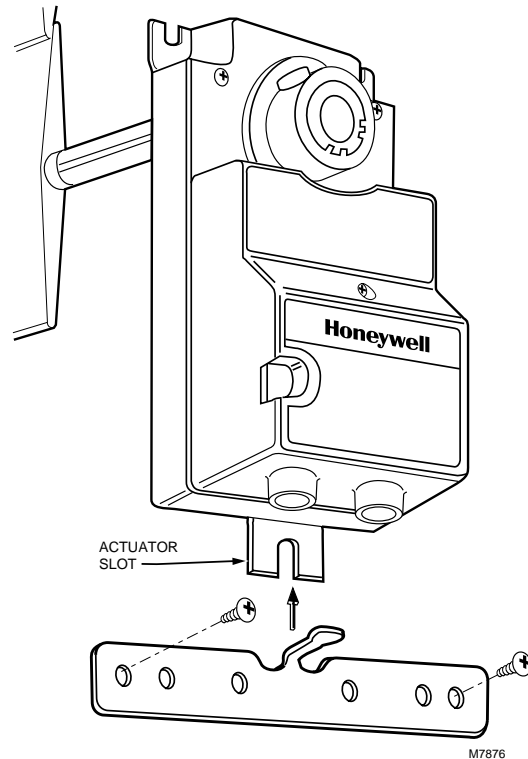

Fig. 2. Installing mounting bracket on ML6284 Non-Spring Return Direct Coupled Damper Actuator. NOTE: Install mounting bracket so mounting bracket tab is centered in actuator slot.

A typical actuator mechanical connection is shown in Fig. 4; wiring diagrams in Fig. 5 through 10.

The ML6284 Non-Spring Return Direct Coupled Damper Actuator can also be three-point mounted using the two front gear housing slots and the adapter bracket. Two screws are secured through the two front gear housing slots and the adapter bracket positioned to secure the rear of the actuator. Three point mounting is used for foot mounting the actuator or internally mounting the actuator in the duct when direct shaft coupling is not possible.

CAUTION



Do not use the actuator as a shaft bearing. The actuator must be used only to supply rotational torque. To prevent damage to the actuator, avoid any side loads to the actuator output coupling bearings.

Preparation

Before installing the ML6284 on the damper shaft, determine the opening direction of the damper shaft (see Fig. 2) to correctly connect the wiring.

Installation

Installing Actuator and Mounting Bracket (Single Point Mounting)

- 1 Place the ML6284 Non-Spring Return Direct Coupled Damper Actuator over the damper shaft.
- 2 Position the actuator for best access to the actuator damper shaft locking screw.
- 3 Install the mounting bracket (see Fig. 2) and adjust it so the bracket tab is midway in the actuator slot. Mark the screw holes for installing the mounting bracket on the damper housing.
- 4 Remove the mounting bracket and actuator.
- 5 Drill or center punch the starting holes for the mounting bracket screws (or use no.10 self-tapping sheet metal screws—not supplied).
- 6 Place the actuator and mounting bracket back into position over the damper shaft and install the mounting bracket screws.
- 7 Move damper shaft either fully clockwise  or fully counterclockwise .

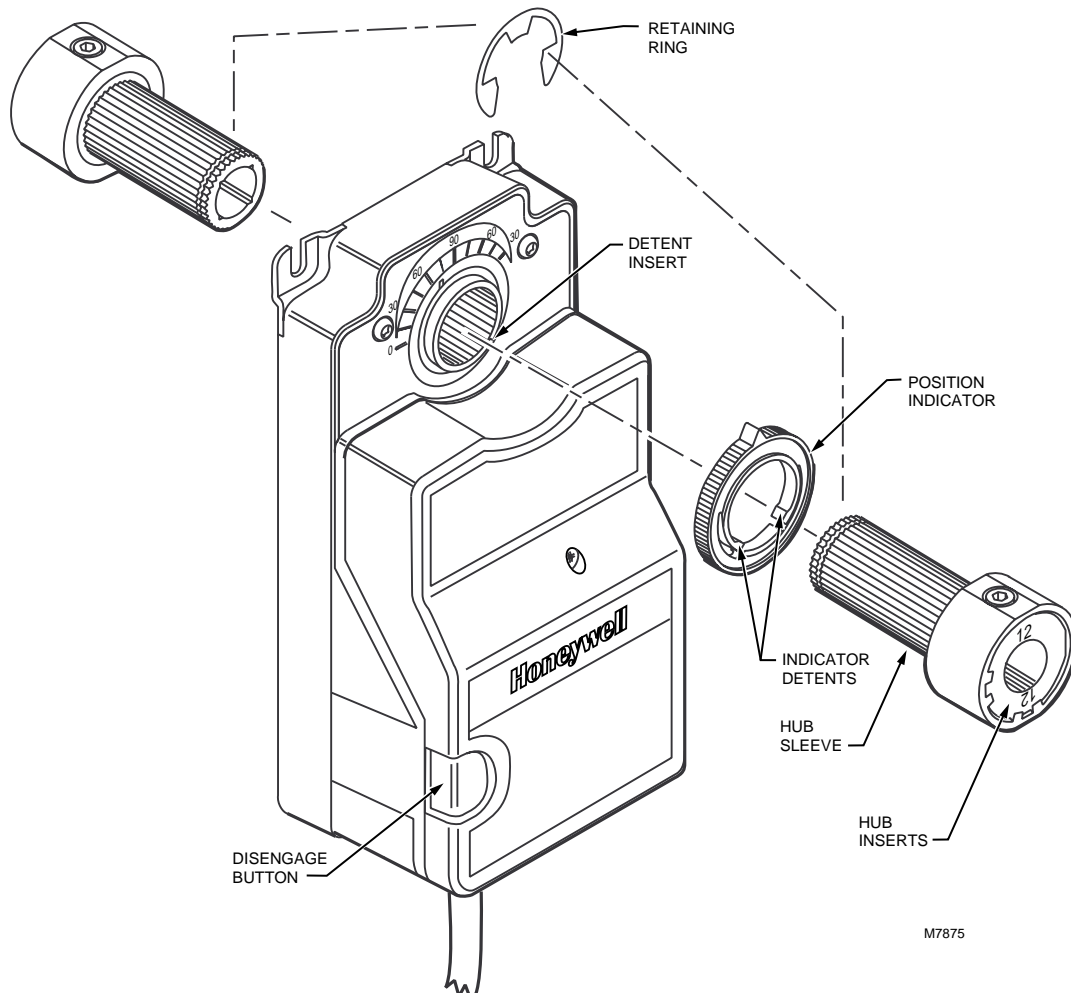



Fig. 3. Mounting hub to inside of actuator.

- 8 Fully depress and hold disengage button while moving the actuator hub either fully clockwise  or fully counterclockwise  to match the damper shaft. Release disengage button.
- 9 Tighten the two 8 mm by 12 mm long set screws firmly against the damper shaft (maximum tightening torque is 100 lb-in.).

Wiring

CAUTION

Disconnect power supply before wiring to prevent electrical shock or equipment damage.

All wiring must comply with local electrical codes, ordinances and regulations. The ML6284 is designed for use with a Class 2 power supply. Voltage and frequency of the transformer used must correspond with the characteristics of the motor and those of the power supply. Standard electrical connection is shown in Fig. 4. See Fig. 5 and 6 for typical wiring connections.

The ML6284 has a plastic housing with two taped holes on the end of the device for 1/2 in. conduit fittings.

ML6284 Models with Factory-mounted Auxiliary Switches (See Fig. 7)



ML6284C,F models have two nonadjustable low voltage rated spdt auxiliary switches that are factory set to make common to normally open at 12° and 82° rotation from the closed counterclockwise stop. See Fig. 7.

IMPORTANT

Actuators driving in parallel may not be synchronized with each other. In normal operation, when all actuators are driven to the fully open or fully closed position, the actuators are again synchronized.

OPERATION

The ML6284 Non-Spring Return Direct Coupled Damper Actuator is designed to be used in ventilating and air conditioning installations to operate dampers, ventilation flaps and louvers requiring up to 150 lb-in. torque.

The ML6284 Non-Spring Return Direct Coupled Damper Actuator is operated by an spdt floating controller. When using an spdt floating controller, the actuator is driven toward its fully open (clockwise ) position when the controller makes B contact and toward the fully closed (counterclockwise ) position when the controller makes W contact. It stops when neither contact is made.

IMPORTANT

The ML6284 can operate with DDC controller that emulates an spdt break-before-make switch. Do not short-cycle the actuator. Short-cycling of the actuator can cause premature failure.

The actuator has a position indicator to show shaft position. As the indicator moves with the shaft, it gives an angular representation of the damper position. There are four distinct positions where the indicator can be placed. The indicator can be removed (by first removing the output hub) to provide proper damper position indication. The indicator can be indexed to show cw or ccw open or closed, using the detents that are 90° apart. See Fig. 3.

The ML6284D and ML6284F models provide a timeout function that removes power from the actuator submotor if the actuator remains in the fully open or fully closed position for longer than a nominal five minutes. This time-out function helps to extend actuator life.

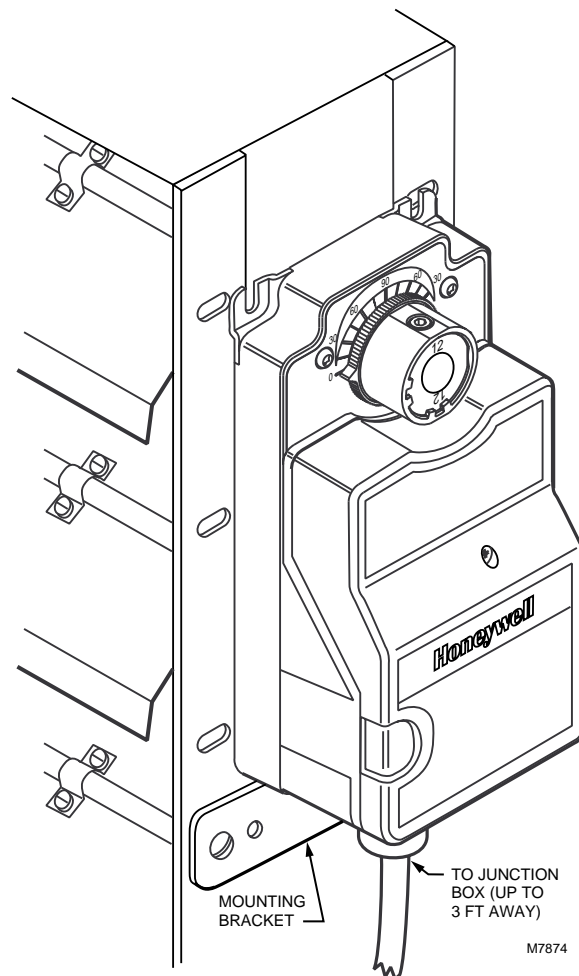

Fig. 4. ML6284 Actuator typical mechanical connection.

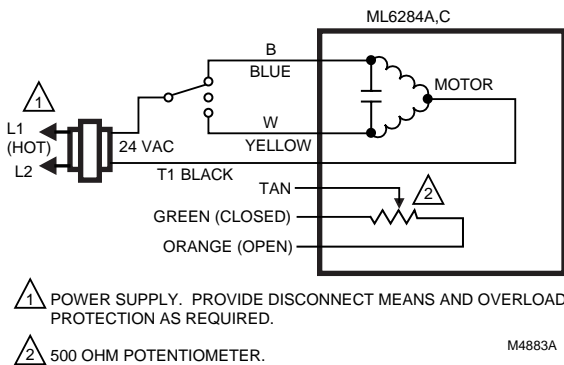

Fig. 5. ML6284A,C typical wiring diagram.

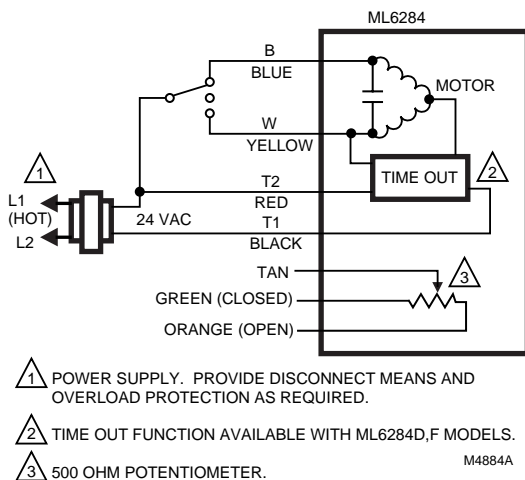

Fig. 6. ML6284D,F typical wiring diagram.

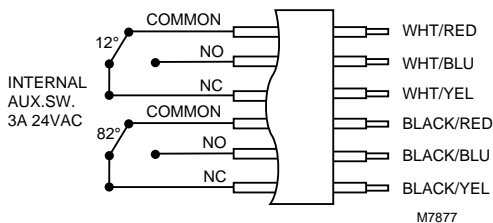

Fig. 7. ML6284 Actuator wiring for auxiliary switches.

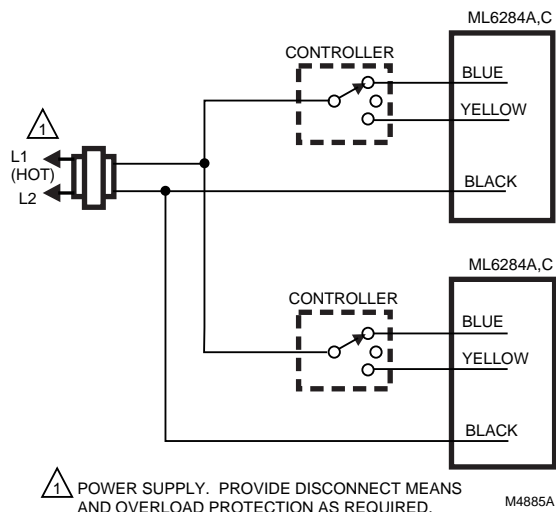

Fig. 8. Common transformer with two controller outputs and two ML6284A,C actuators.

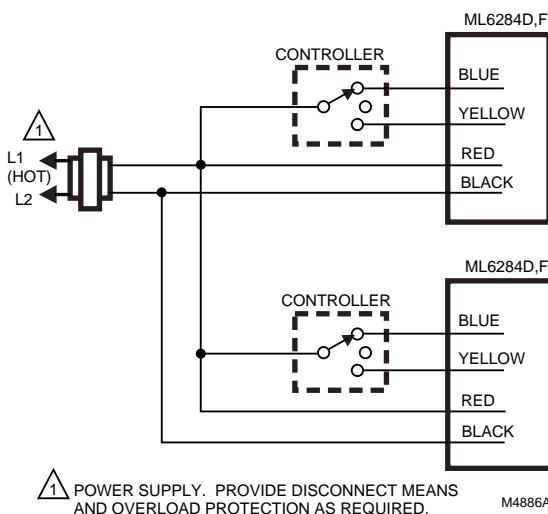

Fig. 9. Common transformer with two controller outputs and two ML6284D,F actuators.

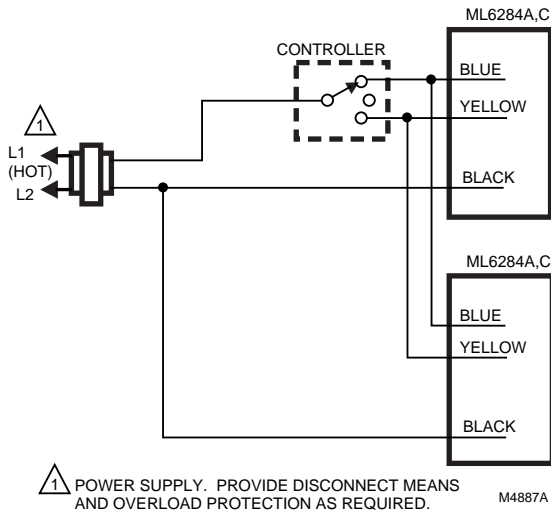

Fig. 10. Common transformer with one controller output and two ML6284A,C actuators.

CHECKOUT









Perform the following steps to checkout the ML6284 Non-Spring Return Direct Coupled Damper Actuator.

- ❶ Check the actuator position indicator and the damper shaft position to see that they agree.
- ❷ If the actuator has timeout function, apply 24 Vac to black (T1) lead and red (T2) lead. See Fig. 5.
- ❸ Apply 24 Vac control signal to blue (B) lead with respect to black (T1) lead (see Fig. 5). Actuator should drive damper open.
- ❹ Apply 24 Vac control signal to yellow (W) lead with respect to black (T1) lead (see Fig. 5). Actuator should drive damper closed.
- ❺ If 24 Vac control signal is removed, actuator should stop.

TROUBLESHOOTING

Perform the following troubleshooting steps if the actuator does not drive, travel full stroke, or operate properly during the checkout.

NOTE: Perform these steps before replacing the actuator.

- ❶ Check the actuator label to verify that proper power and control signal requirements have been met.
- ❷ Check for 24 Vac at actuator black (T1), yellow (W) or blue (B), and red (T2) [if actuator has timeout function] leads when the actuator should be driving. If the voltage is not present or is low, check power supply and controller.
- ❸ If the actuator does not drive in the correct direction when a control signal is applied, reverse the yellow and blue wires.
- ❹ Remove power and fully depress and hold disengage button down while turning damper shaft clockwise  and counterclockwise . If the damper shaft turns freely through the entire 90° stroke and the actuator is installed correctly, replace the actuator.
- ❺ If the damper shaft will not turn freely for the full 90°, check for any bind and make sure the actuator is loose on the mounting bracket. If necessary, adjust mounting bracket to prevent binding.
- ❻ If no binding is noticed in the actuator and damper assembly, remove the actuator and turn the damper shaft clockwise  and counterclockwise . If the damper does not turn freely, repair or replace the damper.
- ❼ If the damper turns, fully depress and hold the actuator disengage button down and turn the actuator hub clockwise  and counterclockwise . If the actuator hub does not turn, replace the actuator.
- ❽ If the actuator and damper turn freely, remount the actuator to the damper in accordance with the instructions in the Installation section. Make sure the actuator and mounting bracket do not bind. Make sure the actuator and damper are both at the same end stop (clockwise  or counterclockwise ) when they are assembled. Hook up the wires and repeat the checkout. Troubleshoot again, if necessary.

Honeywell

Home and Building Control
Honeywell Inc.
1985 Douglas Drive North
Golden Valley, MN 55422

Home and Building Control
Honeywell Limited-Honeywell Limitée
155 Gordon Baker Road
North York, Ontario
M2H 2C9

Helping You Control Your World