

Minimum 60 in-lb torque

- For damper areas up to 15 sq-ft*

Applications



**Direct Coupling -
The Belimo Concept**

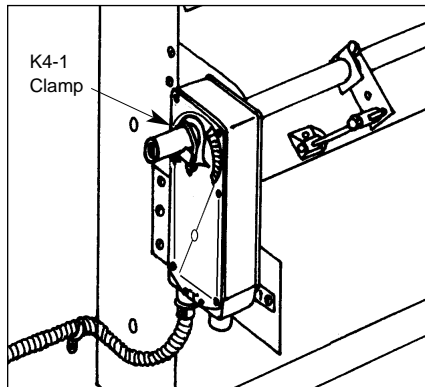

Mount directly to 1.05" jackshafts with accessory clamp.

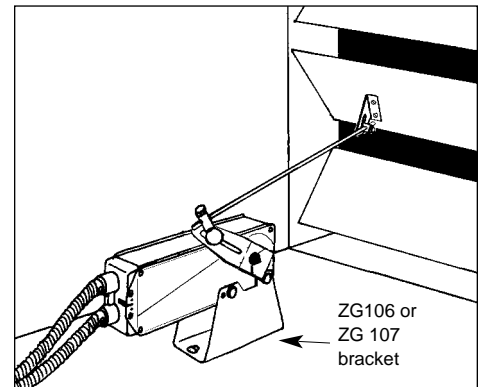

Linkage is available when direct coupling is not possible. (See Mounting Methods Guide 5.1 and Mechanical Accessories Doc 4.2)

NF Series - at a glance

	NF24 us	NF24-S2 us	NF120 us	NF120-S us	NF230 us	NF230-S us	NF24-SR us
Torque: 60 in-lb	●	●	●	●	●	●	●
Power supply : 24 VAC	●	●					●
120 VAC			●	●			
120 VAC					●	●	
Control signal: on-off	●	●	●	●	●	●	
Control signal: proportional 2 to 10 VDC							●
Feedback signal: 2 to 10 VDC							●
Running time motor <75 sec	●	●	●	●	●	●	
motor 150 sec constant							●
spring <60 sec	●	●	●	●	●	●	●
External direction of rotation switch							●
Appliance rated cable, 18 GA	●	●	●	●			●
Built-in auxiliary switch		●		●		●	

* 4 in-lb/ft² damper torque loading. Parallel blade. No edge seals.

A CLOSER LOOK...



- Cut labor costs with simple direct coupling.
- True mechanical spring return - the most reliable failsafe.
- Mount for clockwise or counterclockwise fail-safe.
- Check damper position easily with clear position indicator.
- Don't worry about actuator burn-out. Belimo is overload-proof throughout rotation
- Easy mechanical stop to adjust angle of rotation. (add ZDB-AF2 accessory).
- Need to change control direction? Do it easily with a simple switch. (NF24-SR us)
- Golden Point breather membrane optimizes performance in harsh airstream environments.
- Built-in auxiliary switch(s) is easy to use, offers feedback or signal for additional device. (NF24-S2 us, NF24-S us, NF120-S us, NF230-S us)
- Microprocessor-controlled brushless DC motor increases actuator lifespan and reliability, provides constant running time. (NF24-SR us)
- Rugged metal housing withstands rough handling in the mechanical room.
- 3 ft. appliance rated cable and conduit connector eases installation.



The Belimo Difference

- **Low Installed and Life-Cycle Cost.**
High degree of control accuracy. Easy to install and operate, durable. No maintenance.
- **Long Service Life.**
Components tested before assembly. Final product tested before shipment. Designed with over 20 years of experience in direct coupled applications.
- **Customer Commitment.**
Unconditional warranty. Same-day shipments. Knowledgeable, full-time technical support. Worldwide sales and distribution.

On-off, spring return safety, 24 V



Torque min. 60 in-lb, for control of air dampers

Application:

For on-off, fail-safe control of dampers in HVAC systems. Actuator sizing should be done in accordance with the damper manufacturer's specifications. Control is on-off from an auxiliary contact, or a manual switch.

The actuator is mounted directly to a damper shaft up to 3/4" in diameter by means of its universal clamp, or up to a 1.05" jack-shaft with the optional K4-1 clamp. A crank arm and several mounting brackets are available for applications where the actuator cannot be direct coupled to the damper shaft.

Operation

The NF series actuators provide true spring return operation for reliable fail-safe application and positive close off on air tight dampers. The spring return system provides constant torque to the damper with, and without, power applied to the actuator. The NF series provides 95° of rotation and is provided with a graduated position indicator showing 0° to 95°. The actuator may be stalled anywhere in its normal rotation without the need of mechanical end switches.

The NF24-S us version is provided with 1 built in auxiliary switch. This SPDT switch is provided for safety interfacing or signaling, for example, for fan start-up. The switching function is adjustable between 5° and 85°.

Technical Data	NF24 (-S) us
Power supply	24 VAC ± 20% 50/60 Hz 24 VDC ± 10%
Power consumption	running: 5 W holding: 2.6 W
Transformer sizing	8 VA (class 2 power source)
Electrical connection	3 ft, 18 GA appliance cable 1/2" conduit connector
Overload protection	Electronic throughout 0 to 95° rotation
Electrical protection	Auxiliary switches are double insulated
Angle of rotation	95°, adjustable 30 to 95° w/ accessories
Torque	60 in-lb [7 Nm] constant torque
Direction of rotation	spring return can be selected by CW/CCW mounting
Position indication	visual indicator, 0° to 95° (0° is spring return position)
Auxiliary switches (NF24-S)	1 x SPDT 7A (2.5A) @ 250 VAC, UL listed adjustable 5° to 85°
Running time (nominal)	motor: < 75 sec spring: < 60 sec
Humidity	5 to 95% RH noncondensing
Ambient temperature	-22°F to +122°F [-30°C to +50°C]
Storage temperature	-40°F to +176°F [-40°C to +80°C]
Housing	NEMA type 2 / IP54
Housing material	zinc coated steel
Agency listings	UL 873 listed, CSA 4813 02 certified, CE
Noise level	max. 45 dB (A)
Servicing	maintenance free
Quality standard	ISO 9001
Weight	6.6 lbs (3.0 kg.)

Dimensions (All numbers in brackets are metric.)

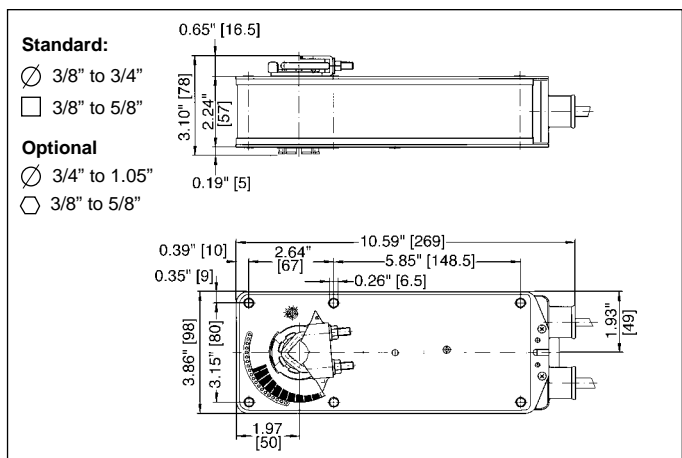

On-off, spring return safety, 24 V

Accessories

AV 10-18	Shaft extension
IND-AF2	Damper position indicator
K4-1	Universal clamp for up to 1.05" dia jackshafts
K4-H	Universal clamp for hexshafts 3/8" to 5/8"
KH-AF	Crankarm for up to 3/4" round shaft
KH-AF-1	Crankarm for up to 1.05" jackshaft
KH-AFV	V-bolt kit for KH-AF and KH-AF-1
Tool-01	10 mm wrench
ZDB-AF2	Angle of rotation limiter
ZG-100	Universal mounting bracket
ZG-101	Universal mounting bracket
ZG-102	Multiple actuator mounting bracket
ZG-103	Universal mounting bracket
ZG-104	Universal mounting bracket
ZG-106	Mounting bracket for Honeywell® Mod IV replacement or new crankarm type installations
ZG-107	Mounting bracket for Honeywell® Mod III or Johnson® Series 100 replacement or new crankarm type installations
ZG-108	Mounting bracket for Barber Colman® MA 3../4..., Honeywell® Mod III or IV or Johnson® Series 100 replacement or new crankarm type installations
ZG-AF	Crankarm adaptor kit for AF/NF
ZG-AF108	Crankarm adaptor kit for AF/NF
ZS-100	Weather shield (metal)
ZS-150	Weather shield (polycarbonate)
ZS-200	Explosion-proof housing
ZS-250	Explosion-proof housing
ZS-300	NEMA 4X housing

Note: When using NF24 us and NF24-S us actuators, only use accessories listed on this page.

Wiring diagrams

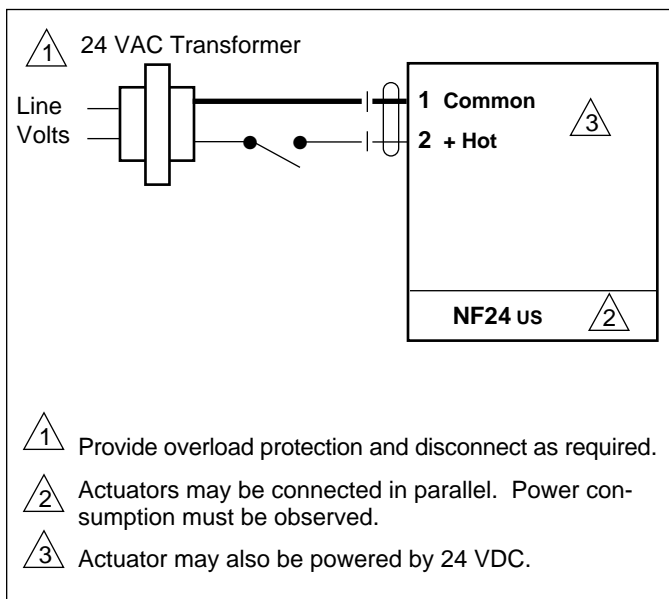

On-off wiring for NF24 us

NF24 us Typical Specification

On-off spring return damper actuators shall be direct coupled type which require no crankarm and linkage and be capable of direct mounting to a jackshaft up to a 1.05" diameter. The actuators must be designed so that they may be used for either clockwise or counterclockwise fail-safe operation. Actuators shall be protected from overload at all angles of rotation. If required, 1 SPDT auxiliary switch shall be provided having the capability of being adjustable. Actuators with auxiliary switches must be constructed to meet the requirements for Double Insulation so an electrical ground is not required to meet agency listings. Actuators shall be UL listed and CSA certified, have a 2 year warranty, and be manufactured under ISO 9001 International Quality Control Standards. Actuators shall be as manufactured by Belimo.

NF24 (-S) us

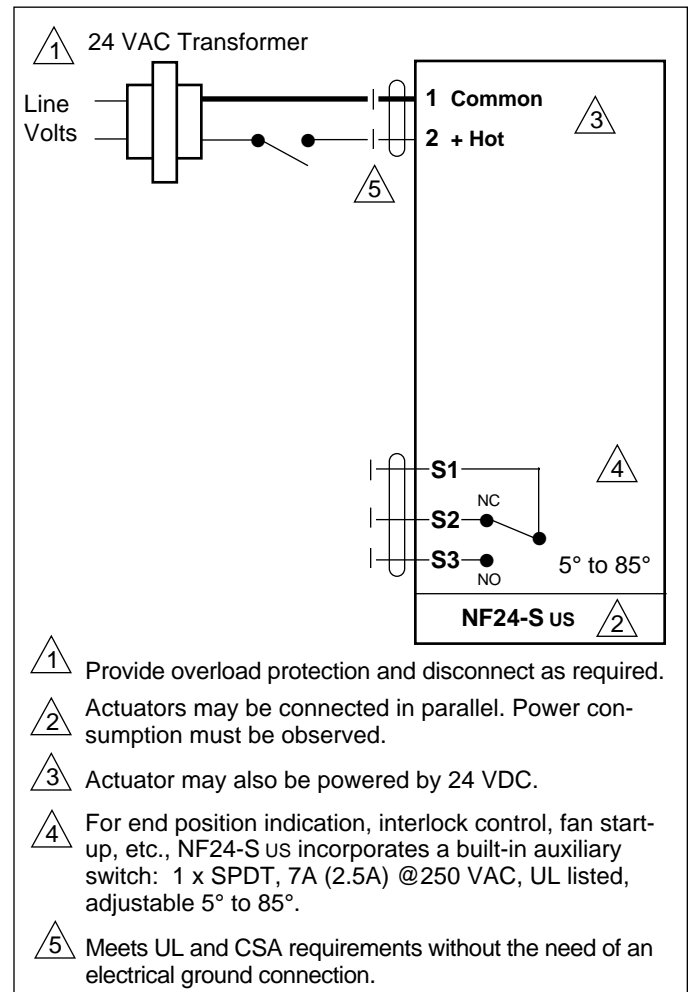

On-off wiring for NF24-S us

On-off, spring return safety, 24 V



Torque min. 60 in-lb, for control of air dampers

Application:

For on-off, fail-safe control of dampers in HVAC systems. Actuator sizing should be done in accordance with the damper manufacturer's specifications. Control is on-off from an auxiliary contact, or a manual switch.

The actuator is mounted directly to a damper shaft up to 3/4" in diameter by means of its universal clamp, or up to a 1.05" jack-shaft with the optional K4-1 clamp. A crank arm and several mounting brackets are available for applications where the actuator cannot be direct coupled to the damper shaft.

Operation

The NF series actuators provide true spring return operation for reliable fail-safe application and positive close off on air tight dampers. The spring return system provides constant torque to the damper with, and without, power applied to the actuator. The NF series provides 95° of rotation and is provided with a graduated position indicator showing 0° to 95°. The actuator may be stalled anywhere in its normal rotation without the need of mechanical end switches.

The NF24-S2 us version is provided with 2 built-in auxiliary switches. These SPDT switches are provided for safety interfacing or signaling, for example, for fan start-up. The switching function at the fail-safe position is fixed at +5°, the other switch function is adjustable between +25° to +85°.

Technical Data	NF24-S2 us
Power supply	24 VAC ± 20% 50/60 Hz 24 VDC ± 10%
Power consumption	running: 5 W holding: 2.6 W
Transformer sizing	8 VA (class 2 power source)
Electrical connection	3 ft, 18 GA appliance cable 1/2" conduit connector
Overload protection	Electronic throughout 0 to 95° rotation
Electrical protection	Auxiliary switches are double insulated
Angle of rotation	95°, adjustable 30 to 95° w/ accessories
Torque	60 in-lb [7 Nm] constant torque
Direction of rotation	spring return can be selected by L/R mounting
Position indication	visual indicator, 0° to 95° (0° is spring return position)
Auxiliary switches	2 x SPDT 7A (2.5A) @ 250 VAC, UL listed one set at +5°, one adjustable 25° to 85°
Running time (nominal)	motor: < 75 sec spring: < 60 sec
Humidity	5 to 95% RH noncondensing
Ambient temperature	-22°F to +122°F [-30°C to +50°C]
Storage temperature	-40°F to +176°F [-40°C to +80°C]
Housing	NEMA type 2 / IP54
Housing material	zinc coated steel
Agency listings	UL 873 listed, CSA 4813 02 certified, CE
Noise level	max. 45 dB (A)
Servicing	maintenance free
Quality standard	ISO 9001
Weight	6.9 lbs (3.0 kg.)

Dimensions (All numbers in brackets are metric.)

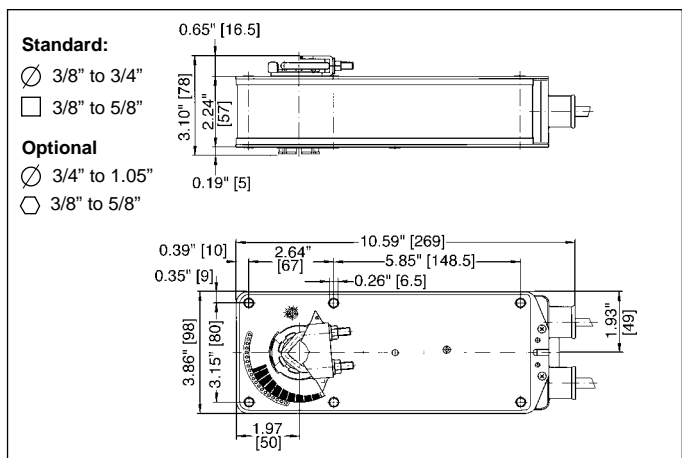

On-off, spring return safety, 24 V

Accessories

- AV 10-18 Shaft extension
- IND-AF2 Damper position indicator
- K4-1 Universal clamp for up to 1.05" dia jackshafts
- K4-H Universal clamp for hexshafts 3/8" to 5/8"
- KH-AF Crankarm for up to 3/4" round shaft
- KH-AF-1 Crankarm for up to 1.05" jackshaft
- KH-AFV V-bolt kit for KH-AF and KH-AF-1
- Tool-01 10 mm wrench
- ZDB-AF2 Angle of rotation limiter
- ZG-100 Universal mounting bracket
- ZG-101 Universal mounting bracket
- ZG-102 Multiple actuator mounting bracket
- ZG-103 Universal mounting bracket
- ZG-104 Universal mounting bracket
- ZG-106 Mounting bracket for Honeywell® Mod IV replacement or new crankarm type installations
- ZG-107 Mounting bracket for Honeywell® Mod III or Johnson® Series 100 replacement or new crankarm type installations
- ZG-108 Mounting bracket for Barber Colman® MA 3../4..., Honeywell® Mod III or IV or Johnson® Series 100 replacement or new crankarm type installations
- ZG-AF Crankarm adaptor kit for AF/NF
- ZG-AF108 Crankarm adaptor kit for AF/NF
- ZS-100 Weather shield (metal)
- ZS-150 Weather shield (polycarbonate)
- ZS-200 Explosion-proof housing
- ZS-250 Explosion-proof housing
- ZS-300 NEMA 4X housing

Note: When using NF24-S2 us actuators, only use accessories listed on this page.

NF24-S2 us Typical Specification

On-off spring return damper actuators shall be direct coupled type which require no crankarm and linkage and be capable of direct mounting to a jackshaft up to a 1.05" diameter. The actuators must be designed so that they may be used for either clockwise or counterclockwise fail-safe operation. Actuators shall be protected from overload at all angles of rotation. 2 SPDT auxiliary switches shall be provided having the capability of being adjustable. Actuators with auxiliary switches must be constructed to meet the requirements for Double Insulation so an electrical ground is not required to meet agency listings. Actuators shall be UL listed and CSA certified, have a 2 year warranty, and be manufactured under ISO 9001 International Quality Control Standards. Actuators shall be as manufactured by Belimo.

Wiring diagrams

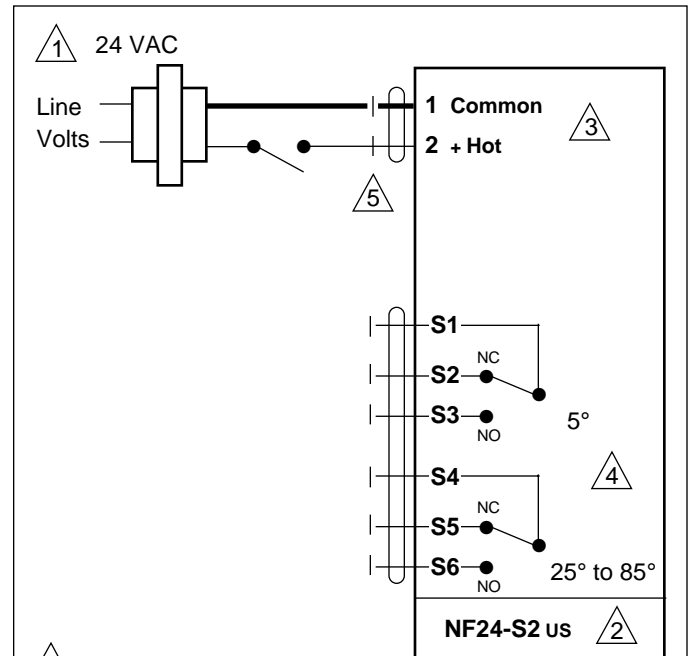

- 1 Provide overload protection and disconnect as required.
- 2 Actuators may be connected in parallel. Power consumption must be observed.
- 3 No ground connection is required.
- 4 For end position indication, interlock control, fan startup, etc., NF24-S2 us incorporates two built-in auxiliary switches: 2 x SPDT, 7A (2.5A) @250 VAC, UL listed, one switch is fixed at +5°, one is adjustable 25° to 85°.
- 5 Meets UL and CSA requirements without the need of an electrical ground connection.

On-off wiring for NF24-S2 us

On-off, spring return safety, 120 or 230 VAC



Torque min. 60 in-lb, for control of air dampers

Application:

For on-off, fail-safe control of dampers in HVAC systems. Actuator sizing should be done in accordance with the damper manufacturer's specifications. Control is on-off from an auxiliary contact, or a manual switch.

The actuator is mounted directly to a damper shaft up to 3/4" in diameter by means of its universal clamp, or up to a 1.05" jack-shaft with the optional K4-1 clamp. A crank arm and several mounting brackets are available for applications where the actuator cannot be direct coupled to the damper shaft.

Operation

The NF series actuators provide true spring return operation for reliable fail-safe application and positive close off on air tight dampers. The spring return system provides constant torque to the damper with, and without, power applied to the actuator. The NF series provides 95° of rotation and is provided with a graduated position indicator showing 0° to 95°. The actuator may be stalled anywhere in its normal rotation without the need of mechanical end switches.

The NF120-S / NF230-S us versions are provided with 1 built-in auxiliary switch. This SPDT switch is provided for safety interfacing or signaling, for example, for fan start-up. The switching function is adjustable between 5° and 85°.

Technical Data	NF120 (-S) us	NF230 (-S) us
Power supply	120 VAC ± 10% 50/60 Hz	230 VAC ± 10% 50/60 Hz
Power consumption	running: 6 W holding: 3.5 W	6 W 3.5W
Transformer sizing	7 VA	7 VA
Electrical connection	3 ft, 18 GA appliance cable 1/2" conduit connector	
Overload protection	Electronic throughout 0 to 95° rotation	
Electrical protection	Auxiliary switches are double insulated	
Angle of rotation	95°, adjustable 30 to 95° w/ accessories	
Torque	60 in-lb [7 Nm] constant torque	
Direction of rotation	spring return can be selected by CW/CCW mounting	
Position indication	visual indicator, 0° to 95° (0° is spring return position)	
Auxiliary switches (-S models)	1 x SPDT 7A (2.5A) @ 250 VAC, UL listed, adjustable 5° to 85°	
Running time (nominal)	motor: < 75 sec spring: < 60 sec	
Humidity	5 to 95% RH noncondensing	
Ambient temperature	-22°F to +122°F [-30°C to +50°C]	
Storage temperature	-40°F to +176°F [-40°C to +80°C]	
Housing	NEMA type 2 / IP54	
Housing material	zinc coated steel	
Agency listings	UL 873 listed, CSA 4813 02 certified, CE	
Noise level	max. 45 dB (A)	
Servicing	maintenance free	
Quality standard	ISO 9001	
Weight	7.3 lbs (3.3 kg.)	

Dimensions (All numbers in brackets are metric.)

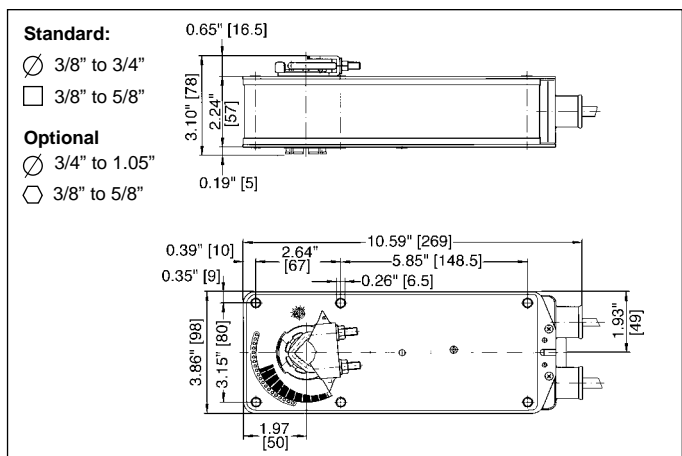

On-off, spring return safety, 120 or 230 VAC

Accessories

AV 10-18	Shaft extension
IND-AF2	Damper position indicator
K4-1	Universal clamp for up to 1.05" dia jackshafts
K4-H	Universal clamp for hexshafts 3/8" to 5/8"
KH-AF	Crankarm for up to 3/4" round shaft
KH-AF-1	Crankarm for up to 1.05" jackshaft
KH-AFV	V-bolt kit for KH-AF and KH-AF-1
Tool-01	10 mm wrench
ZDB-AF2	Angle of rotation limiter
ZG-100	Universal mounting bracket
ZG-101	Universal mounting bracket
ZG-102	Multiple actuator mounting bracket
ZG-103	Universal mounting bracket
ZG-104	Universal mounting bracket
ZG-106	Mounting bracket for Honeywell® Mod IV replacement or new crankarm type installations
ZG-107	Mounting bracket for Honeywell® Mod III or Johnson® Series 100 replacement or new crankarm type installations
ZG-108	Mounting bracket for Barber Colman® MA 3../4.., Honeywell® Mod III or IV or Johnson® Series 100 replacement or new crankarm type installations
ZG-AF	Crankarm adaptor kit for AF/NF
ZG-AF108	Crankarm adaptor kit for AF/NF
ZS-100	Weather shield (metal)
ZS-150	Weather shield (polycarbonate)
ZS-200	Explosion-proof housing
ZS-250	Explosion-proof housing
ZS-300	NEMA 4X housing

Note: When using NF120 us, NF120-S, NF230 us and NF230-S us actuators, only use accessories listed on this page.

Wiring diagrams

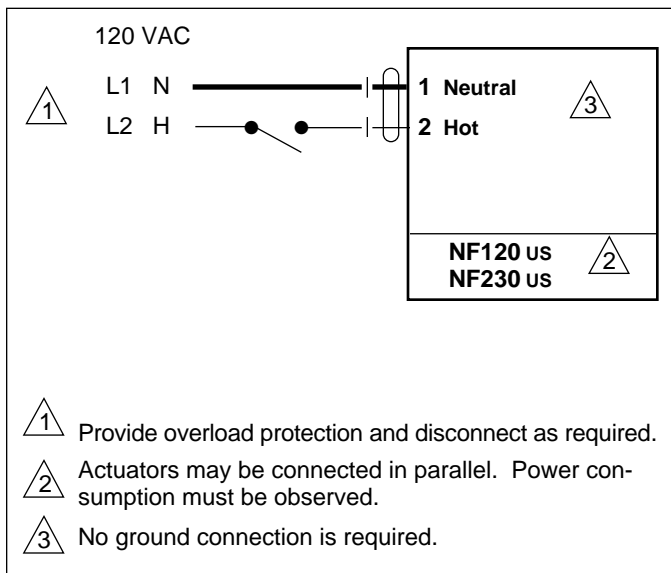

On-off wiring for NF120 us / NF230 us

NF120 us / NF230 us Typical Specification

On-off spring return damper actuators shall be direct coupled type which require no crankarm and linkage and be capable of direct mounting to a jackshaft up to a 1.05" diameter. The actuators must be designed so that they may be used for either clockwise or counterclockwise fail-safe operation. Actuators shall be protected from overload at all angles of rotation. If required, 1 SPDT auxiliary switch shall be provided having the capability of being adjustable. Actuators with auxiliary switches must be constructed to meet the requirements for Double Insulation so an electrical ground is not required to meet agency listings. Actuators shall be UL listed and CSA certified, have a 2 year warranty, and be manufactured under ISO 9001 International Quality Control Standards. Actuators shall be as manufactured by Belimo.

NF120 (-S) us

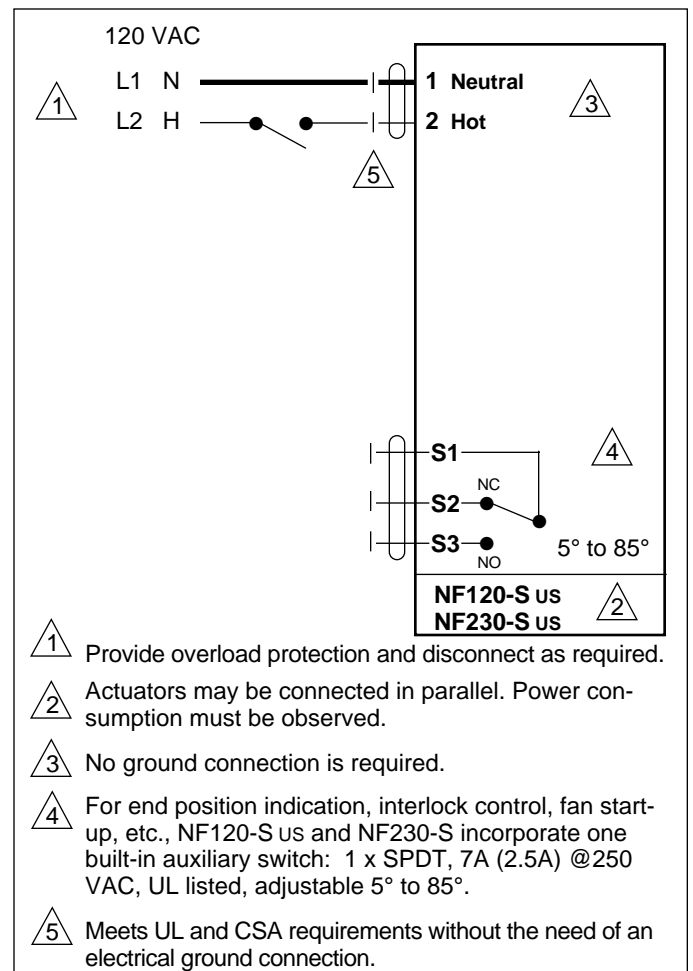

On-off wiring for NF120-S us / NF230-S us

NF24-SR US Spring return direct coupled air damper actuator



Proportional damper actuator, 24 V for 2 to 10 VDC, or 4 to 20 mA control signal.

Output signal of 2 to 10 VDC for position indication



Torque min. 60 in-lb, for control of air dampers

Application

For proportional modulation of dampers in HVAC systems. Actuator sizing should be done in accordance with the damper manufacturer's specifications.

The actuator is mounted directly to a damper shaft up to 3/4" in diameter by means of its universal clamp, or up to a 1.05" jack-shaft with the optional K4-1 clamp. A crank arm and several mounting brackets are available for applications where the actuator cannot be direct coupled to the damper shaft.

The actuator operates in response to a 2 to 10 VDC, or with the addition of a 500Ω resistor, a 4 to 20 mA control input from an electronic controller or positioner. A 2 to 10 VDC feedback signal is provided for position indication or master-slave applications.

Operation

The NF series actuators provide true spring return operation for reliable fail-safe application and positive close-off on air tight dampers. The spring return system provides constant torque to the damper with, and without, power applied to the actuator. The NF series provides 95° of rotation and is provided with a graduated position indicator showing 0° to 95°.

The NF24-SR us uses a brushless DC motor which is controlled by an Application Specific Integrated Circuit (ASIC) and a microprocessor. The microprocessor provides the intelligence to the ASIC to provide a constant rotation rate and to know the actuator's exact fail-safe position. The ASIC monitors and controls the brushless DC motor's rotation and provides a digital rotation sensing function to prevent damage to the actuator in a stall condition. The actuator may be stalled anywhere in its normal rotation without the need of mechanical end switches.

Technical Data	NF24-SR us
Power supply	24 VAC ± 20% 50/60 Hz 24 VDC ± 10%
Power consumption	running: 3 W holding: 1 W
Transformer sizing	6 VA (class 2 power source)
Electrical connection	3 ft, 18 GA appliance cable 1/2" conduit connector
Overload protection	Electronic throughout 0 to 95° rotation
Control signal	Y ₁ 0 to 10 VDC, 0 to 20 mA
Input impedance	100 kΩ (0.1 mA), 500Ω
Operating Range	2 to 10 VDC, 4 to 20mA
Feedback output "U"	2 to 10 VDC (max. 0.5 mA) for 95°
Angle of rotation	95°, adjustable 30° to 95° w/accessory
Torque	60 in-lb [7 Nm] constant torque
Direction of rotation	spring return reversible with CW/CCW mounting; control direction selected by switch: CW=CW with a decrease in signal CCW=CCW with a decrease in signal
Position indication	visual indicator, 0° to 95° (0° is spring return position)
Running time (nominal)	motor: 150 sec constant, independent of load spring: < 60 sec
Humidity	5 to 95% RH noncondensing
Ambient temperature	-22°F to +122°F [-30°C to +50°C]
Storage temperature	-40°F to +176°F [-40°C to +80°C]
Housing	NEMA type 2 / IP54
Housing material	zinc coated metal
Agency listings	UL 873 listed; CSA 4813 02 certified, CE
Noise level	max. 45 dB (A)
Servicing	maintenance free
Quality standard	ISO 9001
Weight	6.0 lbs (2.7 kg.)

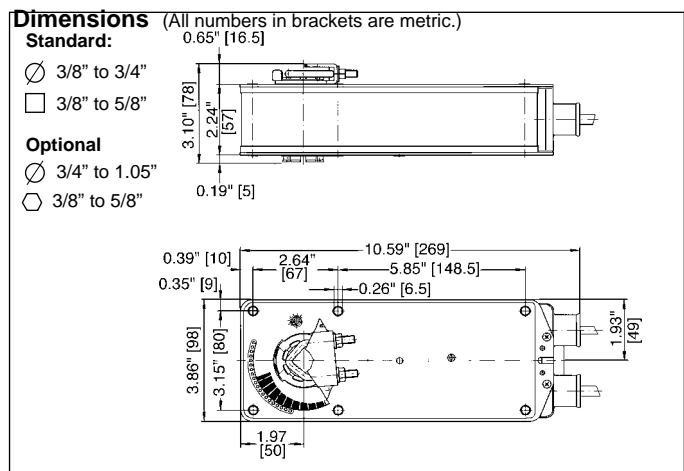

Proportional damper actuator, 24 V for 2 to 10 VDC, or 4 to 20 mA control signal.

Output signal of 2 to 10 VDC for position indication

Accessories

- AV 10-18 Shaft extension
- IND-AF2 Damper position indicator
- K4-1 Universal clamp for up to 1.05" dia jackshafts
- K4-H Universal clamp for hexshafts 3/8" to 5/8"
- KH-AF Crankarm for up to 3/4" round shaft
- KH-AF-1 Crankarm for up to 1.05" jackshaft
- KH-AFV V-bolt kit for KH-AF and KH-AF-1
- PTA-250 Pulse width modulation interface
- Tool-01 10 mm wrench
- SGA24 Min. and/or man. positioner in NEMA 4 housing
- SGF24 Min. and/or man. positioner for flush panel mounting
- ZDB-AF2 Angle of rotation limiter
- ZG-100 Universal mounting bracket
- ZG-101 Universal mounting bracket
- ZG-102 Multiple actuator mounting bracket
- ZG-103 Universal mounting bracket
- ZG-104 Universal mounting bracket
- ZG-106 Mounting bracket for Honeywell® Mod IV replacement or new crankarm type installations
- ZG-107 Mounting bracket for Honeywell® Mod III or Johnson® Series 100 replacement or new crankarm type installations
- ZG-108 Mounting bracket for Barber Colman® MA 3../4.., Honeywell® Mod III or IV or Johnson® Series 100 replacement or new crankarm type installations
- ZG-AF Crankarm adaptor kit for AF/NF
- ZG-AF108 Crankarm adaptor kit for AF/NF
- ZS-100 Weather shield (metal)
- ZS-150 Weather shield (polycarbonate)
- ZS-200 Explosion-proof housing
- ZS-250 Explosion-proof housing
- ZS-300 NEMA 4X housing

Note: When using NF24-SR us actuators, only use accessories listed on this page.

Wiring diagrams

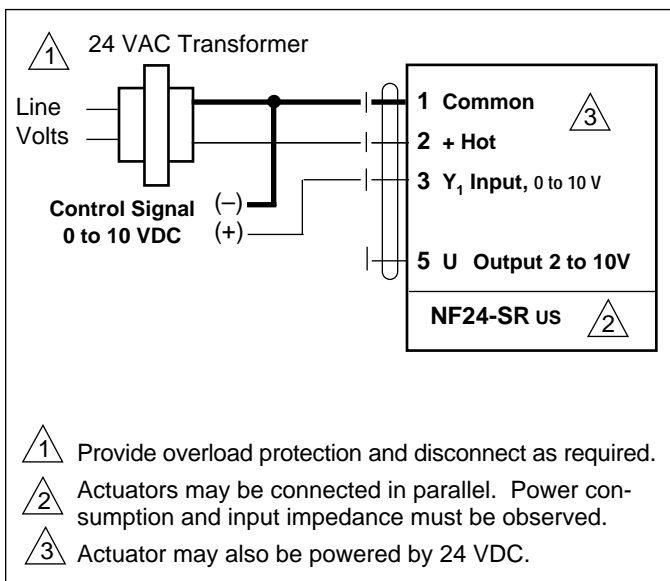

NF24-SR us Typical Specification

Spring return control damper actuators shall be direct coupled type which require no crankarm and linkage and be capable of direct mounting to a jackshaft up to a 1.05" diameter. The actuator must provide proportional damper control in response to a 2 to 10 VDC or, with the addition of a 500Ω resistor, a 4 to 20 mA control input from an electronic controller or positioner. The actuators must be designed so that they may be used for either clockwise or counterclockwise fail-safe operation. Actuators shall use a brushless DC motor controlled by a microprocessor and be protected from overload at all angles of rotation. Run time shall be constant, and independent of torque. A 2 to 10 VDC feedback signal shall be provided for position feedback or master-slave applications. Actuators shall be UL listed and CSA certified, have a 2 year warranty, and be manufactured under ISO 9001 International Quality Control Standards. Actuators shall be as manufactured by Belimo.

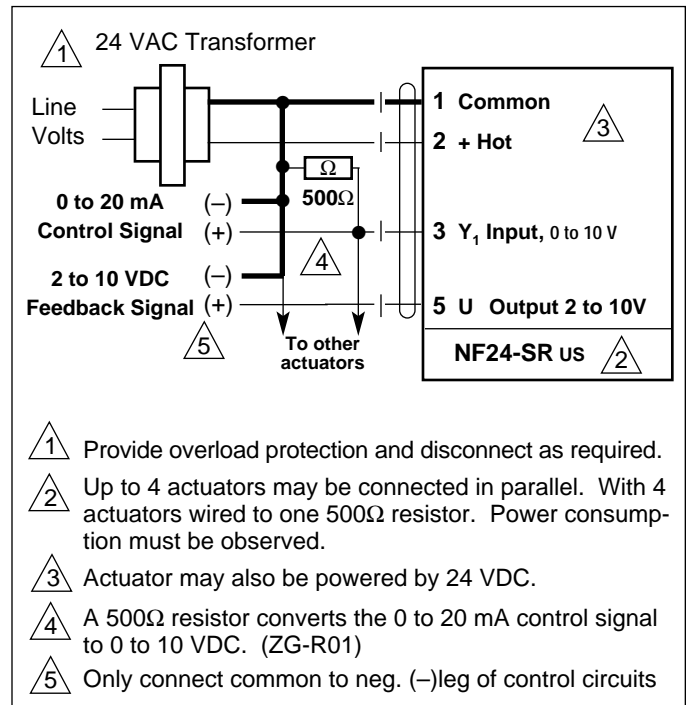

Quick-Mount Visual Instructions for Mechanical Installation

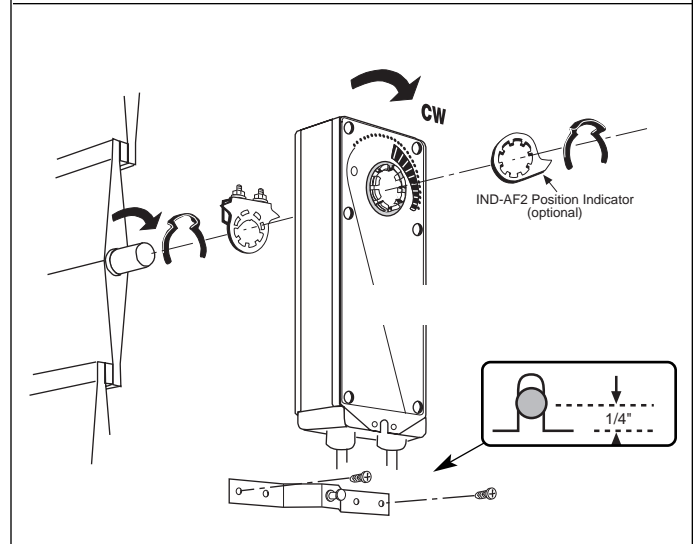
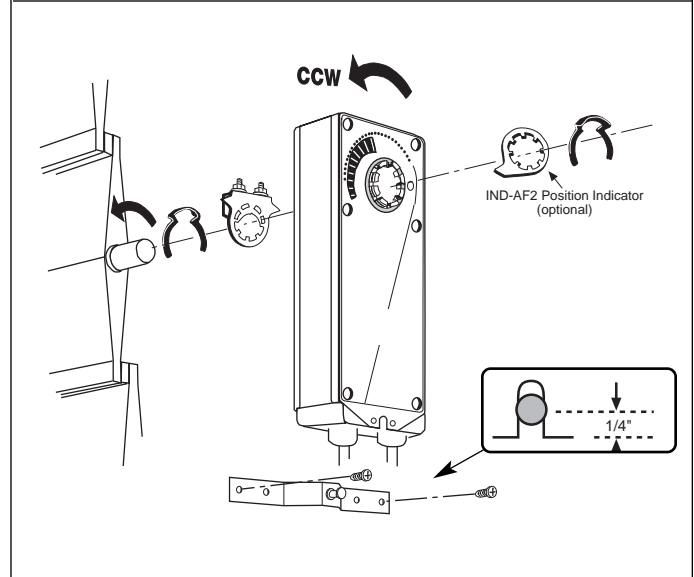
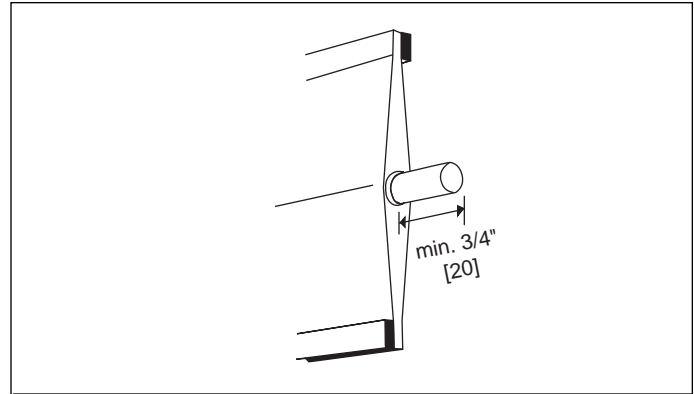
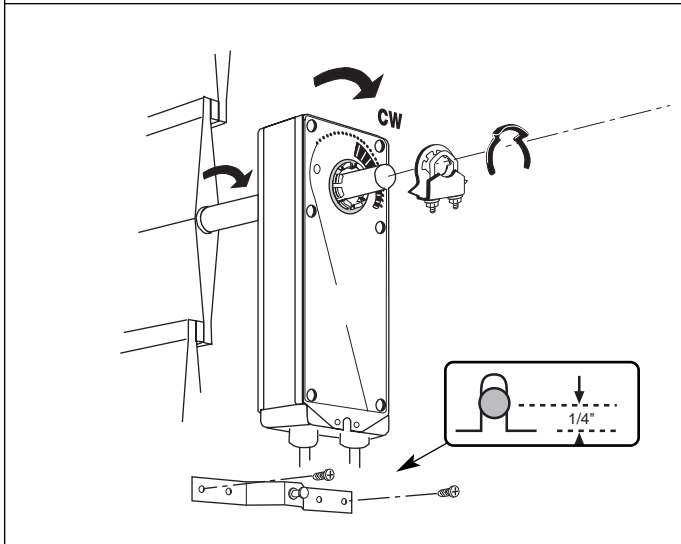
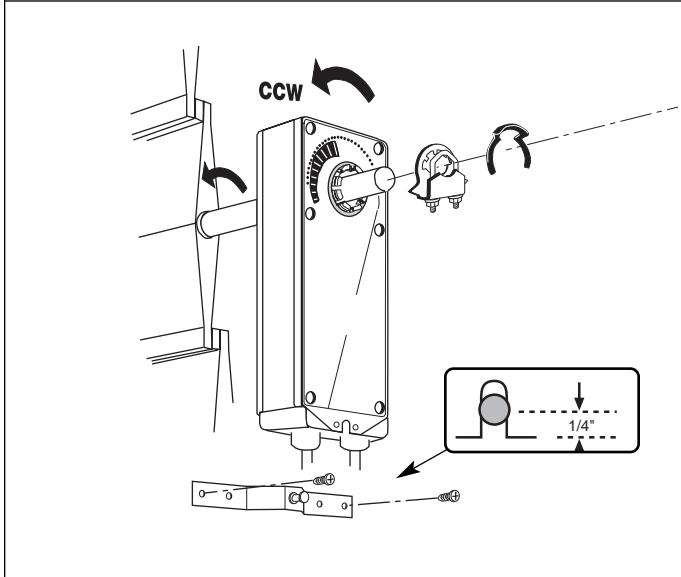
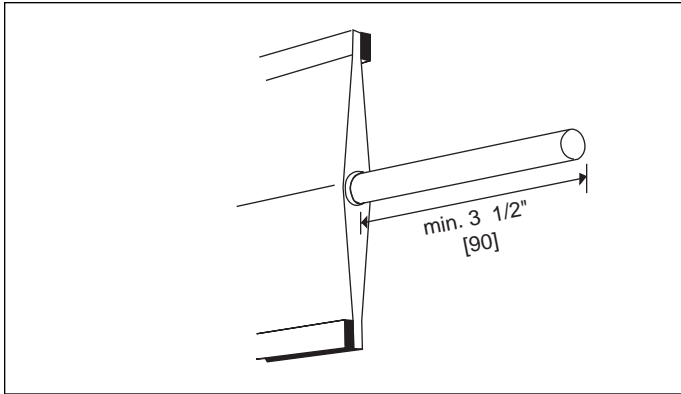

QUICK-MOUNT VISUAL INSTRUCTIONS

1. Rotate the damper to its failsafe position. If the shaft rotates counterclockwise, mount the "CCW" side of the actuator out. If it rotates clockwise, mount the actuator with the "CW" side out.
2. If the universal clamp is not on the correct side of the actuator, move it to the correct side for ease of installation.

3. Slide the actuator onto the shaft and tighten the nuts on the V-bolt with a 10mm wrench to 6-8 ft-lb of torque.
4. Slide the anti-rotation strap under the actuator so that it engages the slot at the base of the actuator. Secure the strap to the duct work with #8 self-tapping screws.

NOTE: Read the "Standard Mounting" instructions, on the next page, for more detailed information.

Mechanical Installation

Determining Torque Loading and Actuator Sizing

Damper torque loadings, used in selecting the correct size actuator, should be provided by the damper manufacturer. If this information is not available, the following general selection guidelines can be used.

Damper Type	Torque Loading
Opposed blade, without edge seals, for non-tight close-off applications	3 in-lb/sq. ft.
Parallel blade, without edge seals, for non-tight close-off applications	4 in-lb/sq. ft.
Opposed blade, with edge seals, for tight close-off applications	5 in-lb/sq. ft.
Parallel blade, with edge seals, for tight close-off applications	7 in-lb/sq. ft.

The above torque loadings will work for most applications under 2 in. w.g. static pressure or 1000 FPM face velocity. For applications between this criteria and 3 in. w.g. or 2500 FPM, the torque loading should be increased by a multiplier of 1.5. If the application calls for higher criteria up to 4 in. w.g. or 3000 FPM, use a multiplier of 2.0.

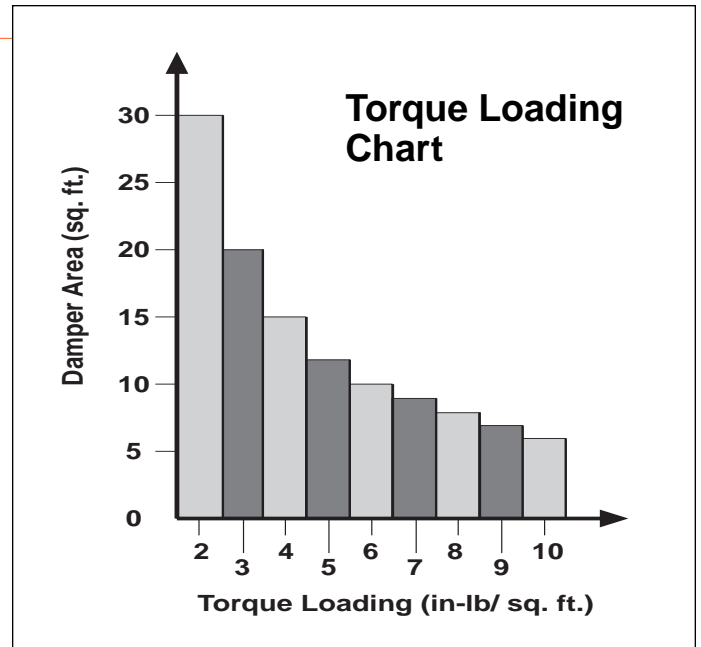

General Information

Belimo actuators should be mounted indoors in a dry, relatively clean environment free from corrosive fumes. If the actuator is to be mounted outdoors, a protective enclosure must be used to shield the actuator.

For new construction work, **order dampers with extended shafts**. Instruct the installing contractor to allow space for mounting and service of the Belimo actuator on the shaft. The damper shaft must extend at least 3 1/2" from the duct. If the shaft extends less than 3 1/2" or if an obstruction blocks access, the shaft can be extended with the AV 10-18 shaft extension or the actuator may be mounted in its short shaft configuration.

Mechanical Operation

The actuator is mounted directly to a damper shaft up to 3/4" in diameter by means of its universal clamp, or up to a 1.05" jackshaft with the optional K4-1 clamp. A crank arm and several mounting brackets are available for applications where the actuator cannot be direct coupled to the damper shaft.

The NF series actuators provide true spring return operation for reliable fail-safe application and positive close-off on air tight dampers. The spring return system provides consistent torque to the damper with, and without, power applied to the actuator.

The NF series provides 95° of rotation and is provided with a graduated position indicator showing 0° to 95°.

The NF...-S versions are provided with 1 built-in auxiliary switch. This SPDT switch is provided for safety interfacing or signaling, for example, for fan start-up. The switching function is adjustable between 5° and 85°. (NF24-S2, with 2 built-in switches, adjustable between +25° and +85°)

Standard Mounting

- See Fig. B. Manually move the damper to the fail-safe position (a) (usually closed). If the shaft rotated counter-clockwise (↺), this is a CCW installation. If the shaft rotated clockwise (↻), this is a CW installation. In a CCW installation, the actuator side marked "CCW" faces out, while in a CW installation, the side marked "CW" faces out. All other steps are identical.
- The actuator is usually shipped with the universal clamp mounted to the "CCW" side of the actuator. To test for adequate shaft length, slide the actuator over the shaft with the side marked "CCW" (or the "CW" side if this is the side with the clamp). If the shaft extends at least 1/8" through the clamp, mount the actuator as follows. If not, go to the *Short Shaft Installation* section.

Mechanical Installation

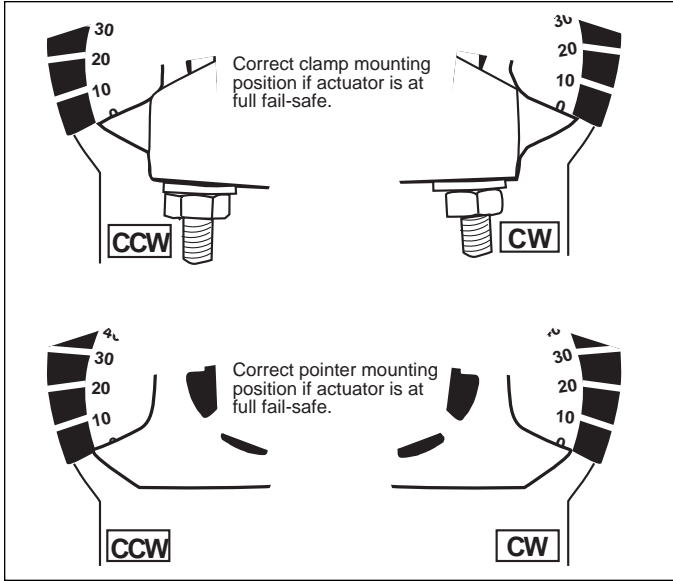

Figure A Universal Clamp and IND-AF2 Position Indicator (optional)

3. If the clamp is not on the correct side as determined in step #1, re-mount the clamp as follows. If it is on the correct side, proceed to step #5. Look at the universal clamp. If you are mounting the actuator with the "CCW" side out, position the clamp so that the pointer section of the tab is pointing to 0° (see Fig. C) and the spline pattern of the clamp mates with spline of the actuator. Slip the clamp over the spline. (Use the same procedure if the "CW" side is out.) If your application requires a mechanical minimum position, read the *Rotation Limitation* section.
4. Lock the clamp to the actuator using the retaining clip.
5. Verify that the damper is still in its full fail-safe position. (a)
6. Mount the spring return actuator to the shaft. Tighten the universal clamp, finger tight only.
7. Mount the anti-rotation strap at the base of the actuator. Slip the stop of the anti-rotation strap in the slot of the base of the actuator. The stud should be centered approximately 1/4" from the end of the slot. Do not tighten the screws.
8. Remove the screw from one end of the mounting bracket and pivot it away from the actuator.
9. Loosen the universal clamp and, making sure not to move the damper shaft, rotate the actuator approximately 5° in the direction which would open the damper.
10. Tighten the universal clamp to the shaft.
11. Rotate the actuator to apply pressure to the damper seals (b) and re-engage the anti-rotation strap (c).
12. Tighten all fasteners.

Short Shaft Installation

If the shaft extends at least 3/4" from the duct, follow these steps:

1. Move damper blades to the fail-safe position (a).
2. Determine the best orientation for the universal clamp on the back of the actuator. The best location would be where you have the easiest access to the V bolt nuts on the clamp.
3. Engage the clamp to the actuator as close as possible to the determined location.
4. Lock the clamp to the actuator using the retainer clip.

5. Mount the spring return actuator to the shaft. Tighten the universal clamp, finger tight only.
6. Mount the anti-rotation strap at the base of the actuator. Do not tighten the screws.
7. Remove the screw from one end of the mounting bracket and pivot it away from the actuator.
8. Loosen the universal clamp and, making sure not to move the damper shaft, rotate the actuator approximately 5° in the direction which would open the damper.
9. Verify that the damper is still in its full fail-safe position.
10. Tighten the universal clamp to the shaft.
11. Rotate the actuator to apply pressure to the damper seals (b) and re-engage the anti-rotation strap (c).
12. Tighten all fasteners.

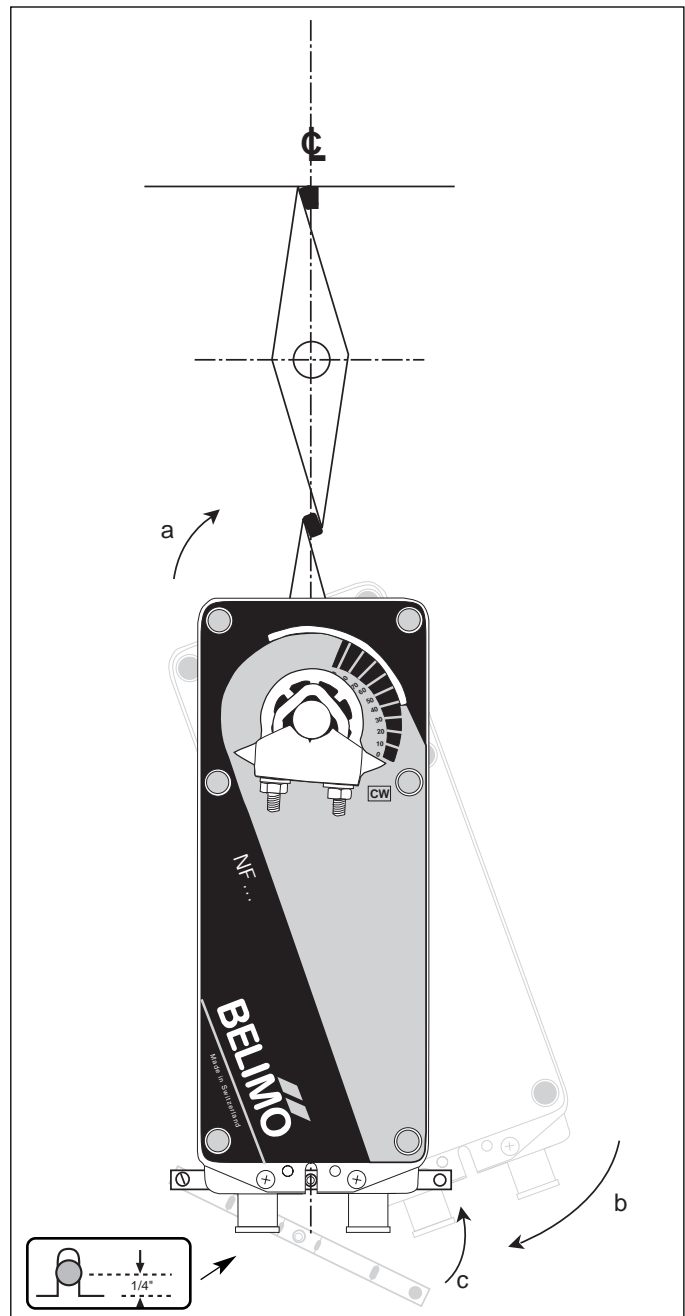

Figure B

Mechanical Installation

Rotation Limitation

The angle of rotation limiter, ZDB-AF2, is used in conjunction with the tab on the universal clamp or IND-AF2 position indicator which comes with the ZDB-AF2. In order to function properly, the clamp or indicator must be mounted correctly. See Fig. A.

The ZDB-AF2 may not work in certain mounting orientations using the ZG-106 or ZG-107 mounting brackets. It will not work with the ZG-108 mounting bracket. Limiting the damper rotation must be accomplished by adjusting the crank arm linkage.

The ZDB-AF2 may be used to control the rotational output of the NF series actuator where a damper has a designed rotation less than 90°. An example would be a 45° or 60° rotating damper.

Damper rotation limiting

1. Determine the amount of damper rotation required.
2. Locate the Angle of Rotation Limiter (ZDB-AF2) on the actuator so that its edge lines up with the degree graduation on the actuator face which corresponds with the required rotation. See Fig. C.

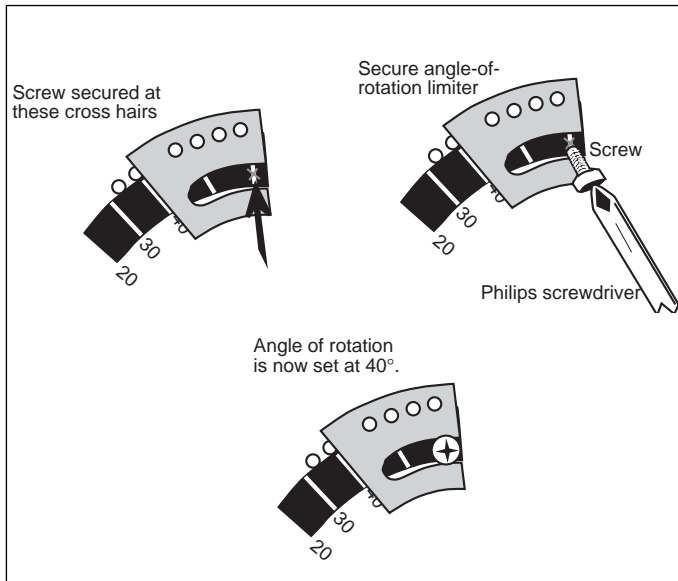

Figure C ZDB-AF2 Securing the Angle of Rotation Limiter

3. Find the appropriate cross-hair location through the slot of the limiter. This is the screw mounting location.
4. Pierce through the label material to allow easy fastening of the retaining screw.
5. Position the limiter back to the desired position, making sure the locating “teeth” on the limiter are engaged into the locating holes on the actuator.
6. Fasten the limiter to the actuator using the self tapping screw provided.
7. Test the damper rotation before applying power and if required, a control signal. Re-adjust if necessary.

Auxiliary Switches

The NF series actuators may be ordered with 1 built-in SPDT auxiliary switch used for safety interfacing or signalling, for example, for fan start-up. The switch position is adjustable between 5° and 85° of rotation. The crank, supplied with the actuator, or a 3mm allen wrench (NF24-S2, with 2 built-in switches, adjustable between +25° and +85°) is used to adjust the switching position. See Fig. D.

1. The actuator must be in its fail-safe position.
2. Insert the crank into the hexagon shaped hole located in the center of the adjustable switch pointer.
3. Rotate the crank until the switch pointer is at the desired switch point in degrees as shown.

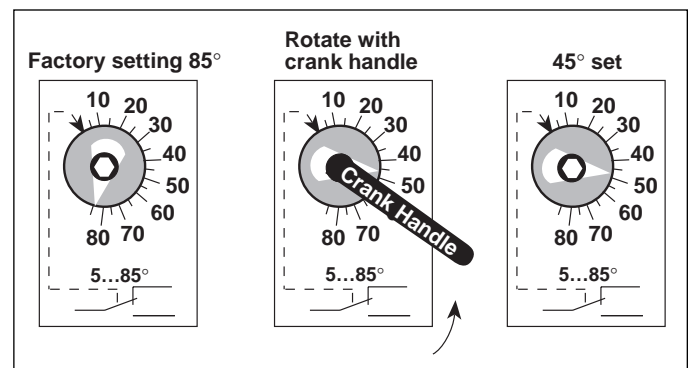

Figure D

Non-direct mounting methods and additional information

Crankarm



KH-AF crankarm including retaining ring. *Caution:* the retaining clip supplied with the clamp is *not* used to mount the KH-AF crankarm.

The KH-AF (-1) crankarm is used in non-direct coupled mounting applications.

Two sizes are available:

KH-AF For round shafts up to 3/4" or square shafts up to 5/8"
 KH-AF-1 For jackshafts up to 1.05"

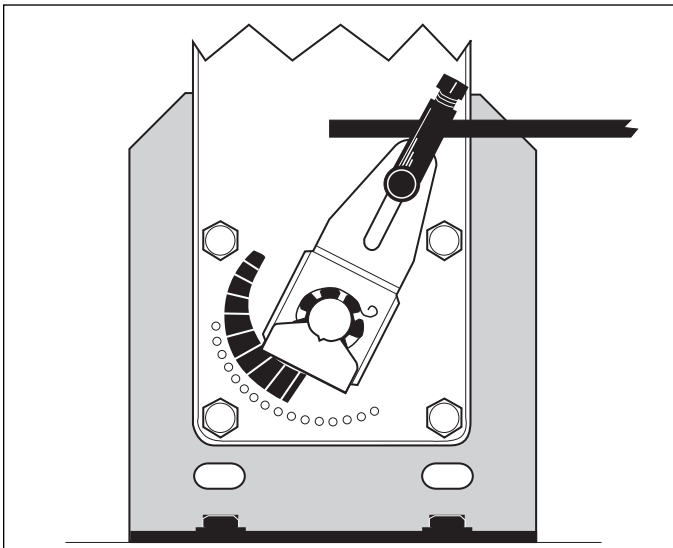

KH-AF Non-direct mounting with ZG-108 mounting bracket

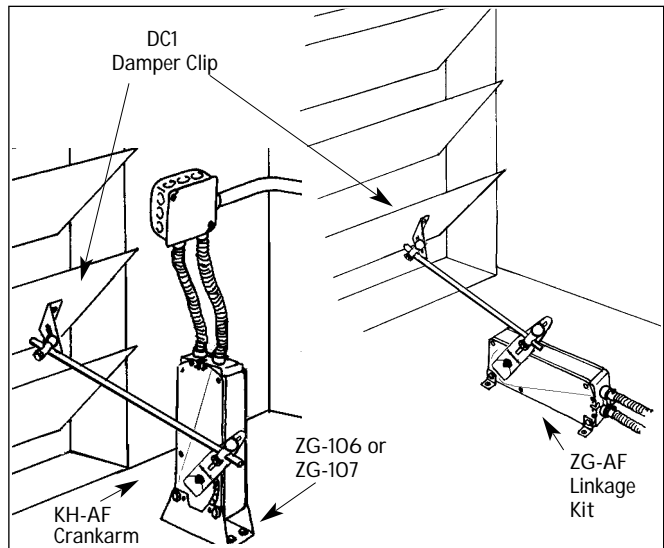

Non-direct mounting using various accessories

Additional Operational Information for NF24-SR us Proportional Actuators

Initialization of the NF24-SR us

When power is initially applied, the microprocessor recognizes that the actuator is at full fail-safe and uses this position as the base for all of its position calculations. The microprocessor will retain the initialized zero during short power failures of up to 20 seconds. For power failures greater than 20 seconds the actuator would naturally return to its full fail-safe position prior to the microprocessor losing its memory. When power is applied again, the actuator will re-initialize the zero position. The microprocessor will keep count of these short power failures until 16 occur. At this point, the microprocessor will automatically drive the actuator to its zero position and re-initialize to correct for any possible error accumulation.

Motor position detection

Belimo brushless DC motors eliminate the need for potentiometers for positioning. Inside the motor are three "Hall Effect" sensors. These sensors detect the spinning rotor and send pulses to the microprocessor which counts the pulses and calculates the position to within 1/3 of a revolution of the motor.

Overload protection

The Belimo NF24-SR us actuator is protected from overload at all angles of rotation. The on board microprocessor constantly monitors the rotation of the DC drive motor inside the actuator and stops the pulses to the motor when it senses a stall condition. The DC motor remains energized and produces full rated torque to the load. This helps ensure that dampers are fully closed and that edge and blade seals are always properly compressed.

Brushless DC motor operation

Belimo's brushless DC motor spins by reversing the poles of stationary electromagnets housed inside rotating permanent magnets. The electromagnetic poles are switched by a microprocessor and a special ASIC (Application Specific Integrated Circuit) developed by Belimo. Unlike the conventional DC motor, there are no brushes to wear or commutators to foul.

General Wiring

General Wiring Instructions

WARNING The wiring technician must be trained and experienced with electronic circuits. Disconnect power supply before attempting any wiring connections or changes. Make all connections in accordance with wiring diagrams and follow all applicable local and national codes. Provide disconnect and overload protection as required. Use copper, twisted pair, conductors only. If using electrical conduit, the attachment to the actuator must be made with flexible conduit.

Always read the controller manufacturer's installation literature carefully before making any connections. Follow all instructions in this literature. If you have any questions, contact the controller manufacturer and/or Belimo.

Transformer(s)

The NF24... actuator requires a 24 VAC transformer and draws a maximum of 8 VA per actuator.

CAUTION: It is good practice to power electronic or digital controllers from a separate power transformer than that used for actuators or other end devices. The power supply design in our actuators and other end devices use half wave rectification. Some controllers use full wave rectification. When these two different types of power supplies are connected to the same power transformer and the DC commons are connected together, a short circuit is created across one of the diodes in the full wave power supply, damaging the controller. Only use a single power transformer to power the controller and actuator if you know the controller power supply uses half wave rectification.

Multiple actuators, one transformer

Multiple actuators may be powered from one transformer provided the following rules are followed:

1. The TOTAL current draw of the actuators (VA rating) is less than or equal to the rating of the transformer.
2. Polarity on the secondary of the transformer is strictly followed. *This means that all No. 1 wires from all actuators are connected to the common leg on the transformer and all No 2 wires from all actuators are connected to the hot-leg. Mixing wire No. 1 & 2 on one leg of the transformer will result in erratic operation or failure of the actuator and/or controls.*

Multiple actuators, multiple transformers

Multiple actuators positioned by the same control signal may be powered from multiple transformers provided the following rules are followed:

1. The transformers are properly sized.
2. All No. 1 wires from all actuators are tied together and tied to the negative leg of the control signal. See wiring diagram page 19.

Wire length for NF... actuators

Keep power wire runs below the lengths listed in the table in Fig. E. If more than one actuator is powered from the same wire run, divide the allowable wire length by the number of actuators to determine the maximum run to any single actuator.

Example for NF24-SR us:

$$3 \text{ actuators, } 16 \text{ Ga wire} \\ 550 \text{ Ft} \div 3 \text{ Actuators} = 183 \text{ Ft. Maximum wire run}$$

Maximum wire length:

NF24(-S) us

Wire Size	Max. Feet.		Wire Size	Max. Feet
12 Ga	1100 Ft.		18 Ga	260 Ft.
14 Ga	700 Ft.		20 Ga	140 Ft.
16 Ga	440 Ft.		22 Ga	75 Ft.

NF120(-S) us / NF230(-S) us

Wire Size	Max. Feet.		Wire Size	Max. Feet
12 Ga	1250 Ft.		18 Ga	320 Ft.
14 Ga	800 Ft.		20 Ga	160 Ft.
16 Ga	500 Ft.		22 Ga	85 Ft.

NF24-SR us

Wire Size	Max. Feet.		Wire Size	Max. Feet
12 Ga	1500 Ft.		18 Ga	375 Ft.
14 Ga	925 Ft.		20 Ga	200 Ft.
16 Ga	550 Ft.		22 Ga	100 Ft.

Figure E

Wire Type and Wire Installation Tips

For most installations, 18 or 16 Ga. cable works well with the NF24... actuators. Use code-approved wire nuts, terminal strips or solderless connectors where wires are joined. It is good practice to run control wires unspliced from the actuator to the controller. If splices are unavoidable, make sure the splice can be reached for possible maintenance. Tape and/or wire-tie the splice to reduce the possibility of the splice being inadvertently pulled apart.

The NF24... proportional actuators have a digital circuit that is designed to ignore most unwanted input signals (pickup). In some situations the pickup may be severe enough to cause erratic running of the actuator. For example, a large inductive load (high voltage AC wires, motors, etc.) running near the power or control wiring may cause excessive pickup. To solve this problem, make one or more of the following changes:

1. Run the wire in metallic conduit.
2. Re-route the wiring away from the source of pickup.
3. Use shielded wire (Belden 8760 or equal). **Ground the shield to an earth ground. Do not connect it to the actuator common.**

NF24-SR us

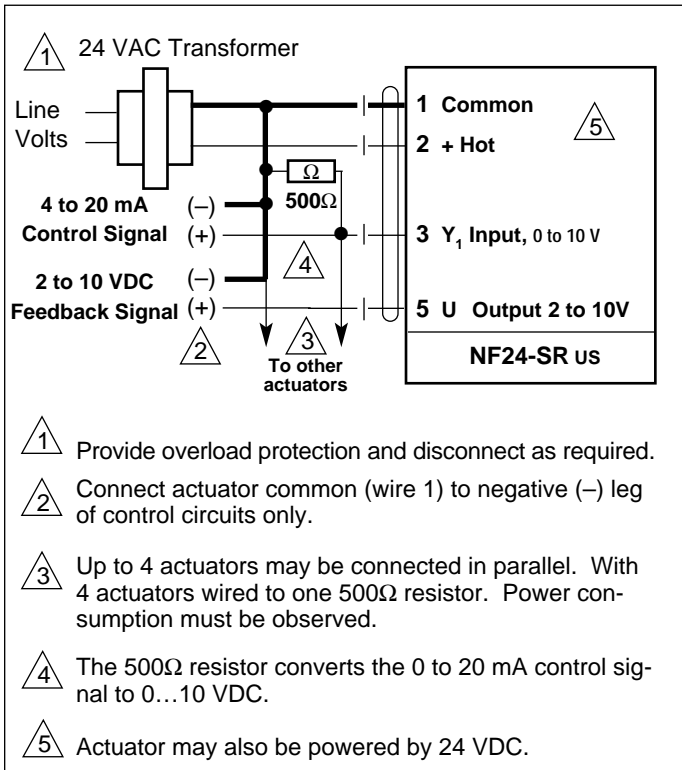

4 to 20 mA control of NF24-SR us with 2 to 10 VDC feedback output.

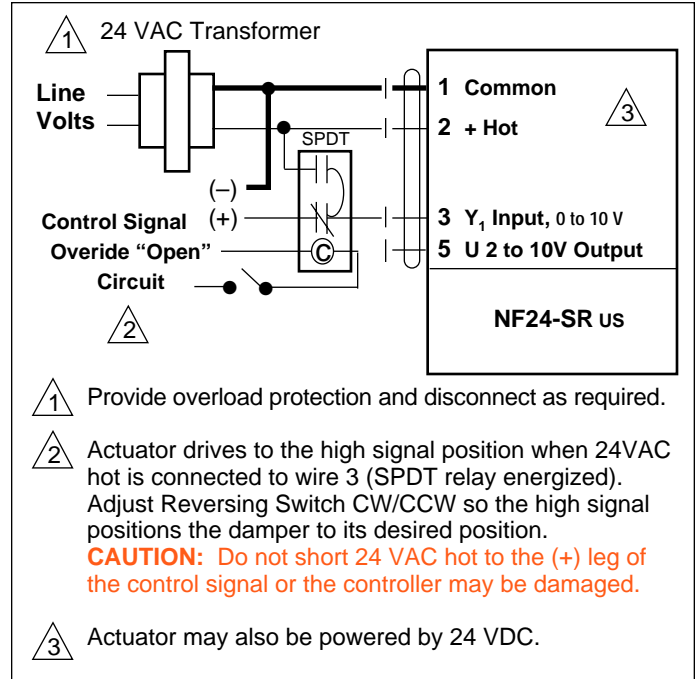

Override open of a NF24-SR us Both the override closed and the override open circuit can be combined on one actuator. Wire the relay contacts in series. Determine which signal has the highest precedence and connect that relay electrically closest to the actuator.

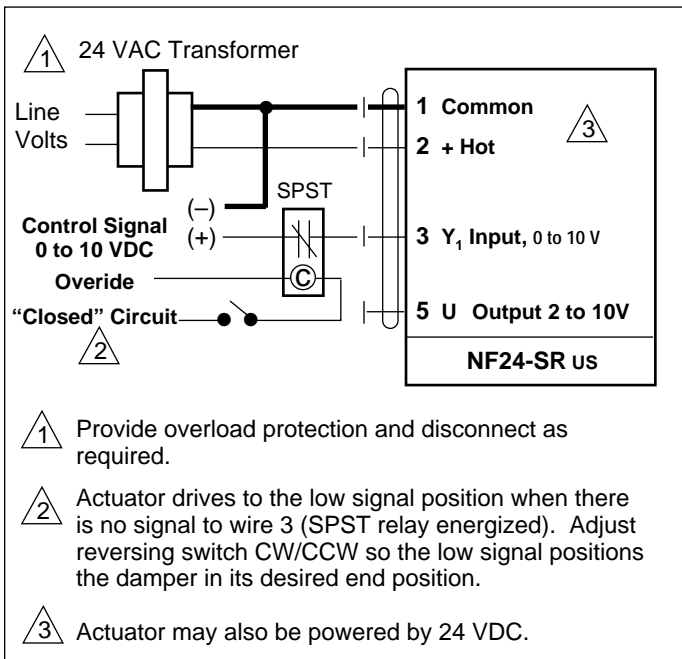

Override closed of a NF24-SR us.

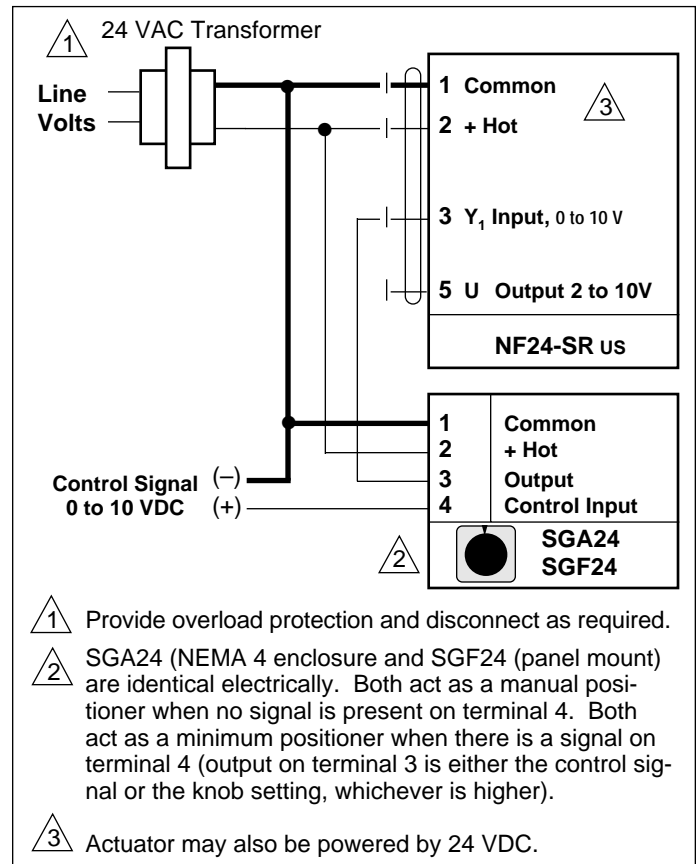

Minimum position control of NF24-SR us from a voltage signal and through a SGA24/SGF24 positioner.

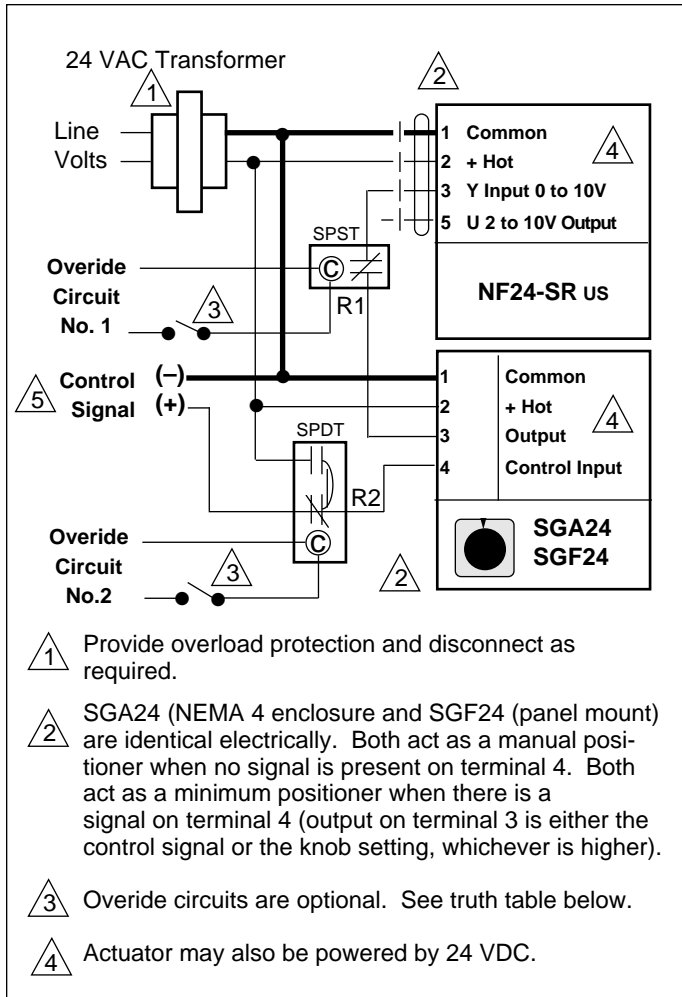

Minimum position control with override circuits of NF24-SR us from a voltage signal and through a SGA24/SGF24 positioner.

Relay R1	Relay R2	Damper Position
De-energized	De-energized	Modulates - min. pos. or control input (Note 3 above)
Energized	De-energized	Close (0 VDC position)
Energized	Energized	Close (0 VDC position)
De-energized	Energized	Open (max VDC position)

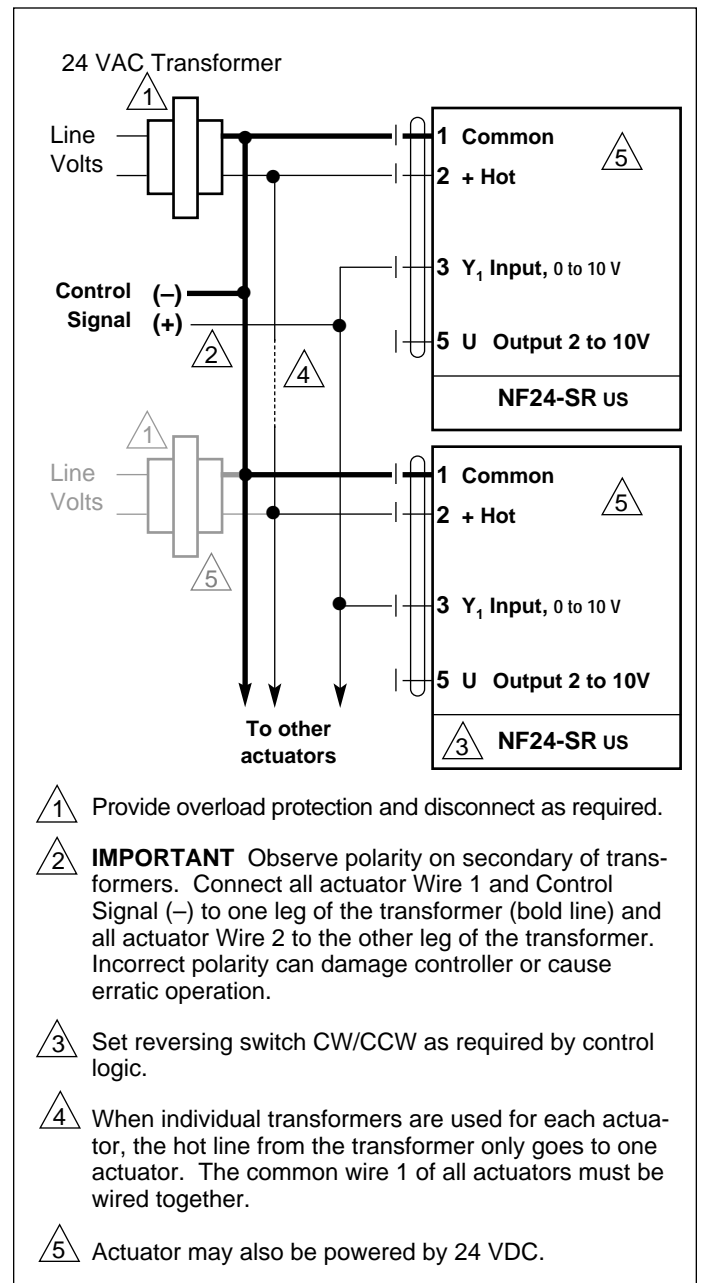

Parallel control of two or more actuators from a voltage signal using either one transformer for all actuators or individual transformers for each actuator.

Instructions For NF24-SR us

NF24-SR us Electrical check-out procedure

Step	Procedure	Expected Response	Gives Expected Response Go To Step...	Does Not Give Expected Response Go To Step...
1.	Control signal is applied to actuator.	Actuator will move to its "Control Signal" position.	Actuator operates properly Step 8	No response at all Step 2 Operation is reversed Step 3 Does not drive toward "Control Signal Position" Step 4
2.	Check power wiring. Correct any problems. See Note 1.	Power supply rating should be \geq the total power requirement of the actuator(s). Minimum voltage of 19.2 VAC or 21.6 VDC.	Power wiring corrected, actuator begins to drive Step 1	Power wiring corrected, actuator still does not drive Step 4
3.	Turn reversing switch to the correct position. Make sure the switch is turned all the way left or right.	Actuator will move to its "Control Signal" position.	Actuator operates properly. Step 8	Does not drive toward "Control Signal Position" Step 4
4.	Make sure the control signal positive (+) is connected to Wire No 3 and control signal negative (-) is connected to wire No. 1. Most control problems are caused by reversing these two wires. Verify that the reversing switch is all the way CCW or CW.	Drives to "Control Signal" position	Actuator operates properly. Step 8	Step 5
5.	Check input signal with a digital volt meter (DVM). Make sure the input is within the range of the actuator. For NF24-SR us this is 2 to 10 VDC or 4 to 20 mA. Note: The input signal must be above the 2 VDC or 4 mA to have the actuator move.	Input voltage or current should be $\pm 1\%$ of what controller's adjustment or programming indicate.	Controller output (actuator input) is correct. Input Polarity Correct. Step 6	Reprogram, adjust repair or replace controller as needed. Step 1
6.	Loosen the nuts on the V-bolt and move the damper by hand from fully closed to fully open..	Damper will go from fully closed to fully open.	Damper moves properly Step 7	Find cause of damper jam and repair. Move damper back to the fully closed position and tighten the nuts. Step 1
7.	Check damper torque requirement.	Torque requirement is \leq actuator's minimum torque.	Defective Actuator. Replace Actuator - See Note 2	Recalculate actuator requirement and correct installation.
8.	Actuator works properly. Test controller by following controller manufacturer's instructions.			

Note 1 Check that the transformer(s) are sized properly.

- If a common transformer is used, make sure that polarity is observed on the secondary. This means connect all No. 1 wires to one leg of the transformer and all No. 2 wires to the other leg of the transformer.
- If multiple transformers are used with one control signal, make sure all No. 1 wires are tied together and tied to control signal negative (-).
- Controllers and actuators must have separate 24 VAC/VDC power sources.

Note 2 If failure occurs within 5 years from original installation date, notify Belimo and give details of the application.