



UHA(X)(S)-Series

RapidTM *Engineering* LLC





Axial Fan Tubular Unit Heaters





Models 150 - 400



Models 30 - 125



-  82% efficiency with use of tubular heat exchangers and inshot burners.
-  Reliable ignition with direct spark ignition burners.
-  Help minimize summer heat build-up with remote fan operation.
-  Longer life and less maintenance with optional stainless steel heat exchangers.

-  Variable air throw direction with adjustable horizontal louvers and optional adjustable vertical louvers.
-  Help reduce dirt build-up on burners and help extend heat exchanger life with separated combustion units.
-  Installation and operation flexibility with rear or top air and flue connections (Models 30 - 125 only).
-  Ideal for smaller spaces with low profile design (Models 30 - 125 only).

1.800.536.3461
www.rapidengineering.com





Technical Data (Models 30-400)

Model		30	45	60	75	100	125	150	175	200	225	250	300	350	400
Total Input	Btu/h x 1000	30	45	60	75	100	125	150	175	200	225	250	300	350	385
Total Output	Btu/h x 1000	24.6	36.9	49.2	61.5	82	102.5	123	143.5	164	184.5	205	246	288.6	315.7
Efficiency		82% - All Models													
Number of Burners		2	3	4	5	6	7	7	8	9	10	11	12	14	14
Gas Connection	in	3/8	3/8	1/2	1/2	1/2	1/2	1/2	1/2	1/2	1/2	1/2	3/4	3/4	3/4
Inlet Pressure (in wc)	NG Min.	5 - All Models													
	LPG Min.	12 - All Models													
	NG & LPG Max.	14 - All Models													
Electrical Supply		120 V / 1 Ø / 60 Hz - All Models													
Full Load Amps @ 120 V		3.0	3.0	4.1	4.1	5.8	5.8	10.6	10.6	10.6	10.6	10.6	11.6	11.6	11.6
Air Volume	CFM	691	691	1376	1376	1902	1902	3500	3500	3716	3716	3716	4663	4663	4663
Recommended Mounting Height	ft	12	12	15	15	20	20	20	20	25	25	25	30	30	30
	m	3.7	3.7	4.6	4.6	6.1	6.1	6.1	6.1	7.6	7.6	7.6	9.1	9.1	9.1
Number of Axial Fans		1	1	1	1	1	1	1	1	1	1	1	2	2	2
Axial Fan Diameter	in	10	10	16	16	16	16	19.7	19.7	19.7	19.7	19.7	16	16	16
	cm	25	25	41	41	41	41	50	50	50	50	50	41	41	41
Horsepower		.06	.06	.08	.08	.2	.2	.3	.3	.3	.3	.3	.4	.4	.4
Fan Motor Amps @ 120 V		1.8	1.8	2.6	2.6	4.3	4.3	4.7	4.7	4.7	4.7	4.7	8.6	8.6	8.6
Fan Motor RPM		1630	1630	1030	1030	1175	1175	1085	1085	1085	1085	1100	1155	1155	1155
Fan Motor Type		SP	SP	SP	SP	PSC	PSC	PSC	PSC	PSC	PSC	PSC	PSC	PSC	PSC
Flue Diameter	in	4 - All Models													
	cm	10 - All Models													
Combustion Air Diameter	in	4	4	4	4	4	4	4	4	4	4	4	5	5	5
	cm	10	10	10	10	10	10	10	10	10	10	10	13	13	13
Approximate Net Weight	lb	65	70	85	90	105	110	217	237	255	265	270	355	375	375
	kg	29.5	31.8	38.6	40.8	47.6	49.9	98.4	107.5	115.7	120.2	122.5	161.0	170.1	170.1
Approximate Shipping Weight	lb	75	80	100	108	130	136	232	242	250	260	300	400	430	430
	kg	34.0	36.3	45.4	49.0	59.0	61.7	109.7	104.3	113.4	118.0	136.1	181.4	195.0	195.0

Clearances to Combustibles (All Models)

		Low Profile Range (Models 30-125)	Standard Profile Range (Models 150-400)
Top***	in	1	6
	cm	2.5	15
Bottom	in	0	3
	cm	0	8
Right	in	1	31*
	cm	2.5	79*
Left	in	18*	6
	cm	46*	15
Rear***	in	18**	24**
	cm	46**	61**
Front	in	118	118
	cm	300	300
Vent	in	2	2
	cm	5	5

* Clearances for servicing.

** Clearances for airflow.

*** These are also installation clearances.

Dimension Data - Low Profile Range (Models 30 - 125)

Model		A	B	C	D	E	F	G	H	J	K	L	M	N	P	Q	R	S
UHA[X][S]30	in	28.5	11.9	20.3	17.6	16.6	25.5	6.0	6.5	6.0	1.6	3.9	6.7	18.2	5.5	4.4	6.8	1.8
	cm	72.4	30.2	51.6	44.7	42.2	64.8	15.2	16.5	15.2	4.1	9.9	17.0	46.2	14.0	11.2	17.3	4.6
UHA[X][S]45	in	28.5	11.9	20.3	17.6	16.6	25.5	6.0	6.5	6.0	1.6	3.9	6.7	18.2	5.5	4.4	6.8	1.8
	cm	72.4	30.2	51.6	44.7	42.2	64.8	15.2	16.5	15.2	4.1	9.9	17.0	46.2	14.0	11.2	17.3	4.6
UHA[X][S]60	in	28.5	17.6	20.3	17.6	16.6	25.5	6.3	6.1	2.8	1.6	3.4	6.7	18.2	5.5	4.4	6.8	1.8
	cm	72.4	44.7	51.6	44.7	42.2	64.8	16.0	15.5	7.1	4.1	8.6	17.0	46.2	14.0	11.2	17.3	4.6
UHA[X][S]75	in	28.5	17.6	20.3	17.6	16.6	25.5	6.3	6.1	2.8	1.6	3.4	6.7	18.2	5.5	4.4	6.8	1.8
	cm	72.4	44.7	51.6	44.7	42.2	64.8	16.0	15.5	7.1	4.1	8.6	17.0	46.2	14.0	11.2	17.3	4.6
UHA[X][S]100	in	28.5	22.6	20.3	17.6	16.6	25.5	7.0	6.0	2.4	1.6	3.4	6.7	18.2	6.3	4.4	6.8	1.8
	cm	72.4	57.4	51.6	44.7	42.2	64.8	17.8	15.2	6.1	4.1	8.6	17.0	46.2	16.0	11.2	17.3	4.6
UHA[X][S]125	in	28.5	22.6	20.3	17.6	16.6	25.5	7.0	6.0	2.4	1.6	3.4	6.7	18.2	6.3	4.4	6.8	1.8
	cm	72.4	57.4	51.6	44.7	42.2	64.8	17.8	15.2	6.1	4.1	8.6	17.0	46.2	16.0	11.2	17.3	4.6

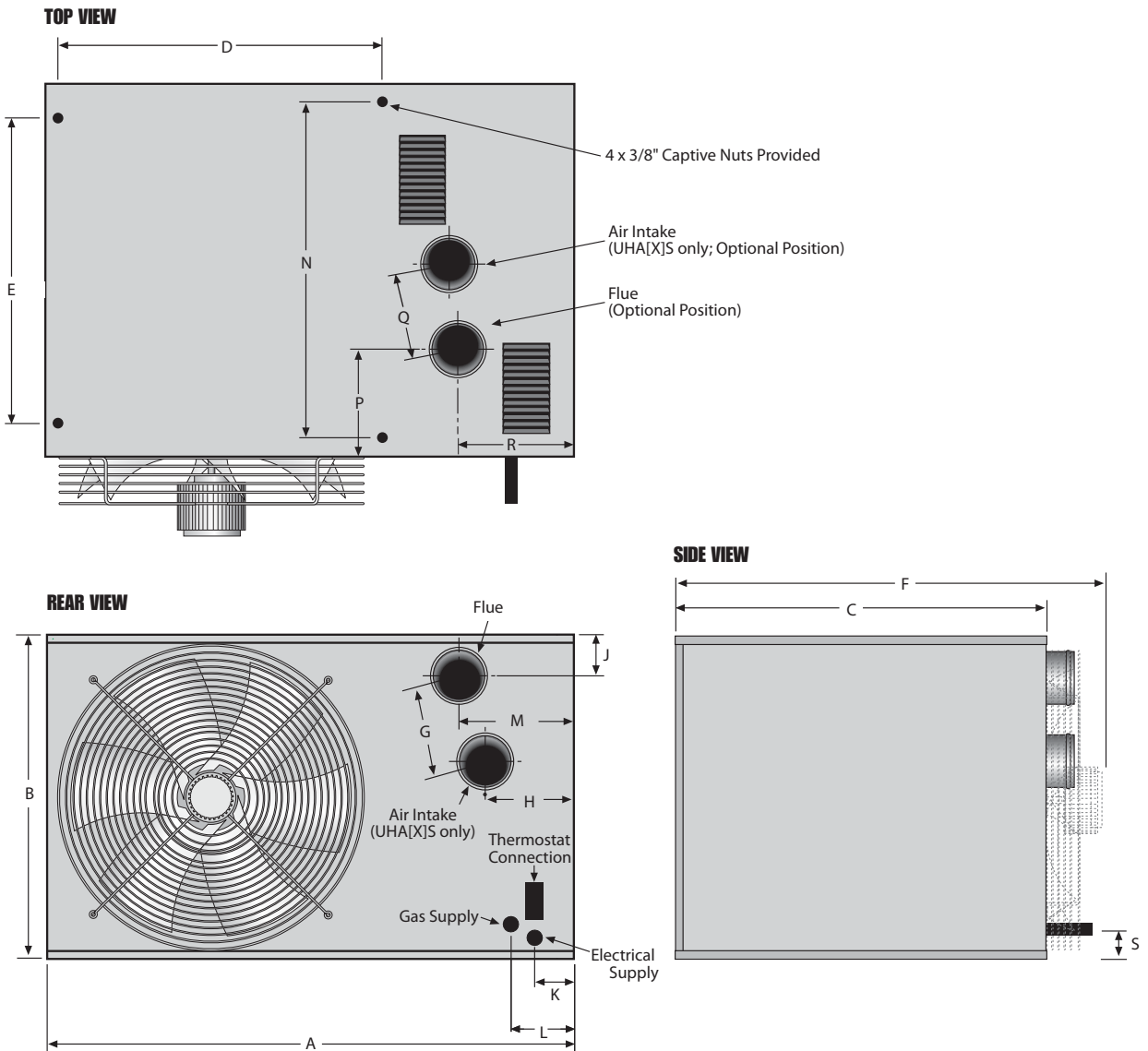

Dimension Data - Standard Profile Range (Models 150 - 400)

Model		A	B	C	D	E	F	G	H	J	K	L	M	N
UHA(X)(S)150	in	42.4	26.7	25.5	17.6	19.4	30.0	6.0	8.6	15.3	3.4	5.9	2.4	6.5
	cm	107.7	67.8	64.8	44.7	49.3	76.2	15.2	21.8	38.9	8.6	15.0	6.1	16.5
UHA(X)(S)175	in	42.4	26.7	25.5	17.6	19.4	30.0	6.0	8.6	15.3	3.4	5.9	2.4	6.5
	cm	107.7	67.8	64.8	44.7	49.3	76.2	15.2	21.8	38.9	8.6	15.0	6.1	16.5
UHA(X)(S)200	in	42.4	35.0	25.5	17.6	19.4	32.0	6.0	8.3	17.2	3.4	5.9	2.4	6.5
	cm	107.7	88.9	64.8	44.7	49.3	81.3	15.2	21.1	43.7	8.6	15.0	6.1	16.5
UHA(X)(S)225	in	42.4	35.0	25.5	17.6	19.4	32.0	6.0	8.3	17.2	3.4	5.9	2.4	6.5
	cm	107.7	88.9	64.8	44.7	49.3	81.3	15.2	21.1	43.7	8.6	15.0	6.1	16.5
UHA(X)(S)250	in	42.4	35.0	25.5	17.6	19.4	32.0	6.0	8.3	17.2	3.4	5.9	2.4	6.5
	cm	107.7	88.9	64.8	44.7	49.3	81.3	15.2	21.1	43.7	8.6	15.0	6.1	16.5
UHA(X)(S)300	in	52.3	43.2	25.5	24.7	19.4	30.0	7.0	11.2	13.8	6.2	8.7	2.4	6.5
	cm	132.8	109.7	64.8	62.7	49.3	76.2	17.8	28.4	35.1	15.7	22.1	6.1	16.5
UHA(X)(S)350	in	52.3	43.2	25.5	24.7	19.4	30.0	7.0	11.2	13.8	6.2	8.7	2.4	6.5
	cm	132.8	109.7	64.8	62.7	49.3	76.2	17.8	28.4	35.1	15.7	22.1	6.1	16.5
UHA(X)(S)400	in	52.3	43.2	25.5	24.7	19.4	30.0	7.0	11.2	13.8	6.2	8.7	2.4	6.5
	cm	132.8	109.7	64.8	62.7	49.3	76.2	17.8	28.4	35.1	15.7	22.1	6.1	16.5

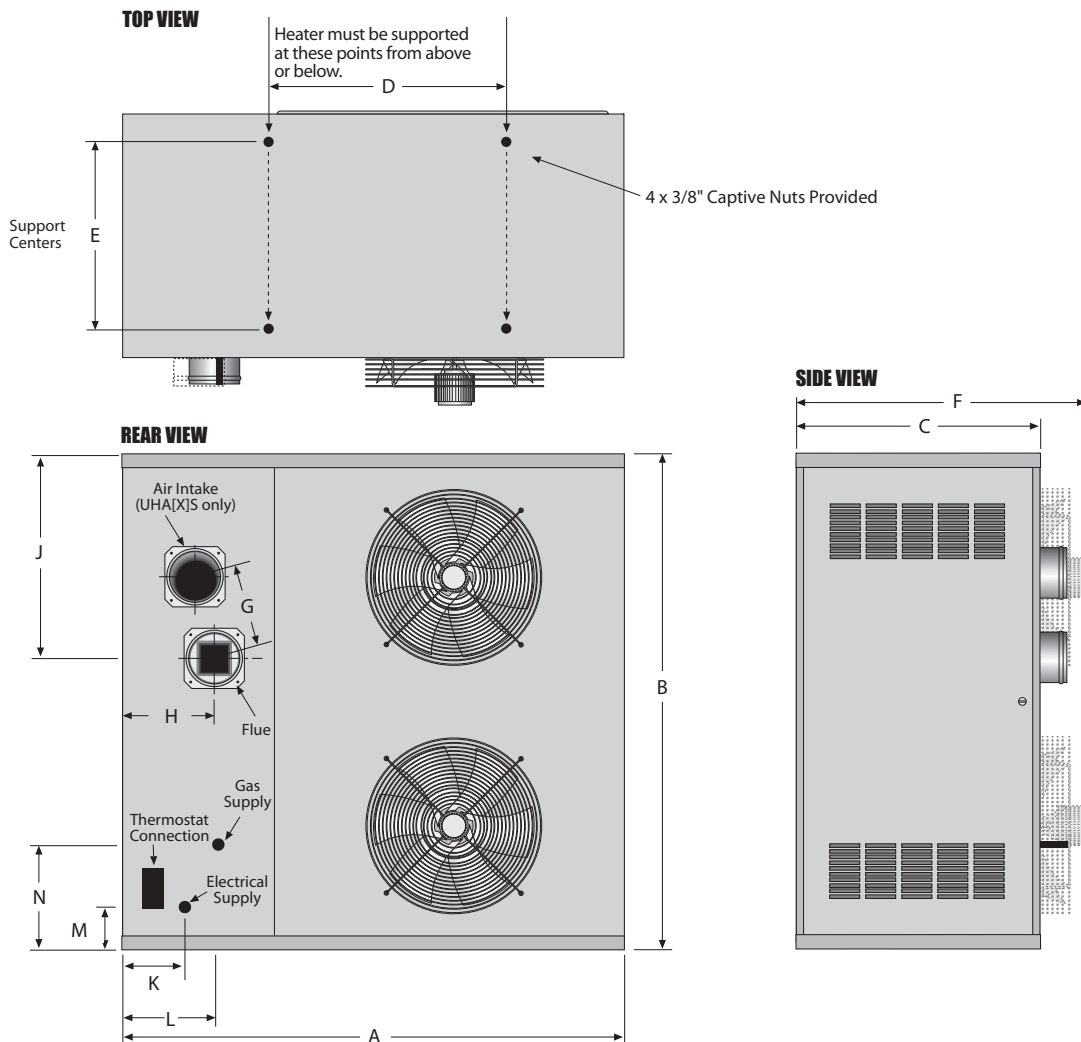

RAPID™ UHA(X)(S)-SERIES VENTING

Non-Separated Combustion Heater

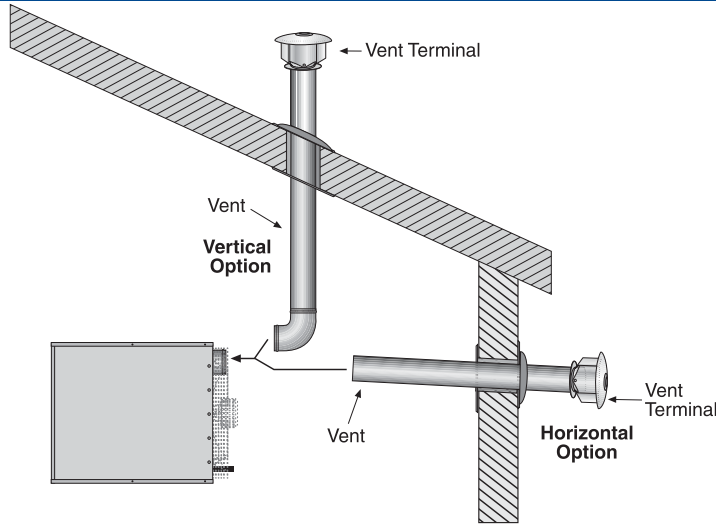

Non-separated combustion heaters use air from the heated space for combustion. The combustion air is drawn into the unit through openings in the access door and then into the open burner box. The products of combustion must be vented to the outdoors. Flue can be run either vertically through a roof penetration or horizontally through a wall penetration.

Separated Combustion Heater Without Concentric Vent Kit

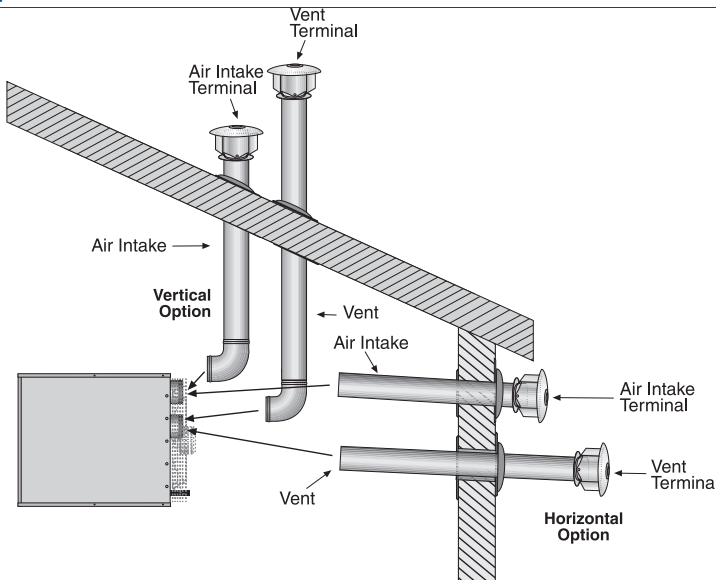

Separated combustion heaters use air from outside of the heated space for combustion. The combustion air is drawn into the unit's enclosed burner box through a piece of ductwork that is extended out to a flange mounted on the heater's cabinet. Ductwork must be run from that flange either vertically through a roof penetration or horizontally through a wall penetration to allow the intake of combustion air. The products of combustion must be vented to the outdoors. Flue can be run either vertically through a roof penetration or horizontally through a wall penetration. Venting a separated combustion heater without a concentric vent kit will result in two building penetrations, one for the air intake ductwork and one for the flue ductwork.

Separated Combustion Heater with Concentric Vent Kit

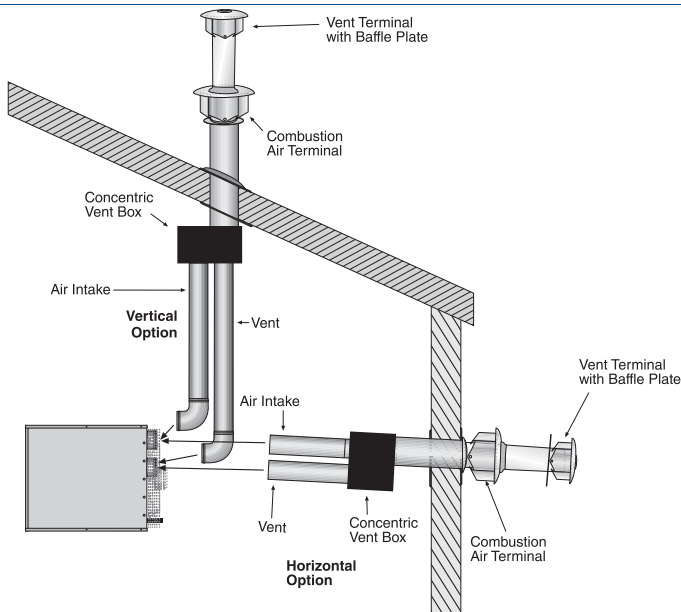

Separated combustion heaters use air from outside of the heated space for combustion. The combustion air is drawn into the unit's enclosed burner box through a piece of ductwork that is extended out to a flange mounted on the heater's cabinet. Ductwork must be run from that flange either vertically or horizontally to the concentric vent box. The products of combustion must be vented to the outdoors. Flue can be run either vertically or horizontally to the concentric vent box. The air intake and flue ductwork will be combined into a single concentric vent at the concentric vent box. This single piece of concentric vent will then continue horizontally or vertically to a single building penetration.

Thank You For Your Business!

Installation Code and Annual Inspections:

All installation and service of RAPID™ equipment must be performed by a contractor qualified in the installation and service of equipment sold and supplied by Rapid Engineering LLC and conform to all requirements set forth in the Rapid Engineering LLC manuals and all applicable governmental authorities pertaining to the installation, service and operation of the equipment. To help facilitate optimum performance and safety, Rapid Engineering LLC recommends that a qualified contractor conduct, at a minimum, annual inspections of your RAPID™ equipment and perform service where necessary, using only replacement parts sold and supplied by Rapid Engineering LLC.

Further Information: Applications, engineering and detailed guidance on systems design, installation and equipment performance is available through RAPID™ representatives. Please contact us for any further information you may require, including the Installation, Operation and Service Manual.

**These products (with the exception of the UHA[X][S]30-75) are not for residential use.
This document is intended to assist licensed professionals in the exercise of their professional judgment.**

Rapid Engineering LLC

1100 Seven Mile Road NW
Comstock Park, MI 49321
Telephone: +1.616.784.0500
Toll Free: 800.536.3461
Fax: +1.616.784.1910

www.rapidengineering.com

© 2010 Rapid Engineering LLC

All rights reserved. No part of this work covered by the copyrights herein may be reproduced or copied in any form or by any means – graphic, electronic, or mechanical, including photocopying, recording, taping, or information storage and retrieval systems – without written permission of Rapid Engineering LLC.