



## **HVAC Indirect-Fired 8500 Series Features & Benefits**

- Discharge air free of combustion by-products.
- High efficiency due to three or four pass heat exchanger design.
- Longer part longevity: Motors, belts and bearings are placed out of the airstream.
- Rugged, heavy-duty construction: Unit cabinet is supported by welded steel frame. Casing is finish-coated to help protect against corrosion.
- Evaporative and mechanical cooling packages available.
- Modular design allows for custom configurations to meet customers' needs.

### **Reliable, Efficient System Operation Provided by:**

- Double-width, double-inlet, forward-curved Class I, AMCA rated centrifugal fan
- System that does not contaminate heated air with combustion by-products
- Operation of fan only in warm weather to enjoy free ventilation cooling
- Full-floating, stainless steel primary heat exchanger
- Multiple blowers on tubular steel blower shafts (on most models)
- Mounting and wiring of all necessary operating starters, relays, switches, safety control and fuses
- Variable pitch drive pulley (up through 10 hp)
- ODP motors with adjustable motor mounts

### **Long Lasting Construction Provided by:**

- Rugged angle steel base frame on every unit section to withstand the rigors of shipping and handling
- Fabricated sheet panels that virtually eliminate rattling or rumbering
- Extra long life self aligning bearings sized for industrial duty
- White painted finish
- Double-wall heat exchanger module

### **Ease of Maintenance Provided by:**

- Modular designed sections
- Convenient access to heat exchangers and blower module for field service
- Optional service platforms on upright units

### **8500-Series Controls' Options:**

- Remote Station with room or discharge thermostat for easy operation and remote temperature adjustment
- UL listed
- Audible alarm for flame failure
- Clogged filter indicator
- Service Receptacle
- Unit-mounted on/off toggle switch

### **8500-Series Options:**

- Natural gas, propane gas or oil burners available
- Roof curbs and vertical stands simplify mounting
- Fresh air hood with birdscreen helps protect against water entrainment
- V-bank filter section with disposable or cleanable filters for longer equipment life of internal components
- Motorized two-position inlet or discharge damper for exfiltration control
- Gas trains approved to FM, IRI, or other special code requirements
- Insulated and/or weatherized sections available for outdoor units



## Model Configurations

### Make-up Air (MUA) Models

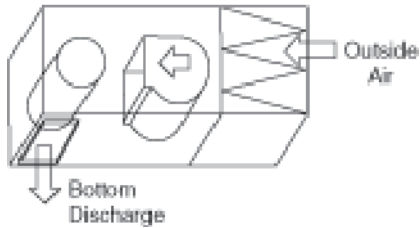

**Design:** 100% replacement air with a fixed discharge air volume

**Function:** Supplies direct replacement air for building mechanical exhaust

**Application:** Used as a make-up air for paint booths and other industrial processes which incorporate mechanical exhaust

### Fixed Recirculation (FR) Models

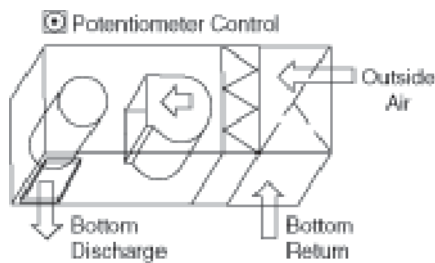

**Design:** Manual modulation of outdoor air from 0% to 100% with use of mixing box and potentiometer

**Function:** Provides efficient, low-cost heating where minimum ventilation rates are required

**Application:** Used in warehouses, distribution centers, retail outlets, etc

### Air Management (AM) Models

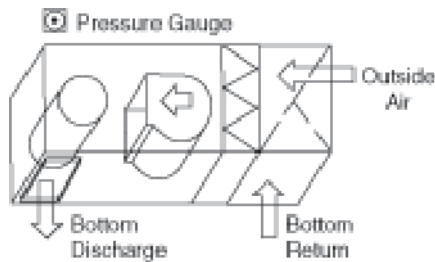

**Design:** Automatic modulation of outdoor air from 0% to 100% with the use of mixing box and pressure gauge

**Design:** Automatic modulation of outdoor air from 0% to 100% with the use of mixing box and pressure gauge

**Application:** Used in industrial and commercial buildings that have air quality and specific air management requirements



## **Optional Cooling Packages**

### **Evaporative Cooling**

Rapid™ 8500-Series evaporative cooling system is an economical cooling solution. It requires no air-cooled condenser, no chiller or cooling tower, no chilled water pumps or distribution piping/insulation, no major motor control center or electrical gear. Operating costs are a fraction of similar-capacity mechanical refrigeration systems.

Evaporative cooling works when warm air passes over specially treated wetted media. The heat passes from the air to the wetted media, causing the water to evaporate and inside air to cool.

### **Mechanical Cooling**

For situations requiring temperature and humidity levels lower than the performance parameters available with outdoor air alone or with evaporative cooling, RAPID™ 8500-Series offer a broad range of cooling options.

Cooling options can be added by simply installing coil sections equipped with the appropriate cooling coils and a condensing unit or chiller. The versatility afforded by the coil section enables you to utilize DX refrigerant, chilled water or other types of cooling coils in your system.

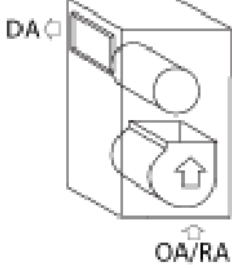
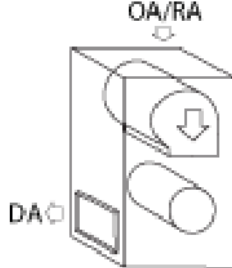
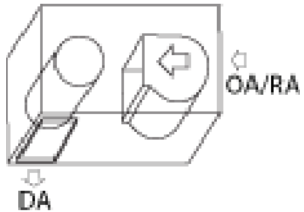
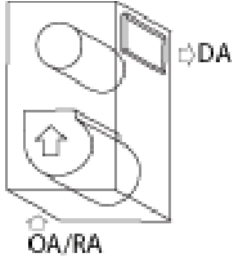
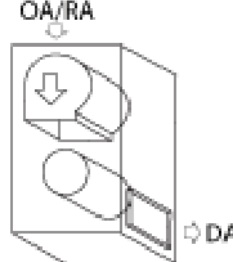
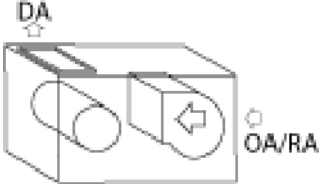
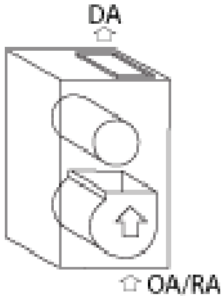
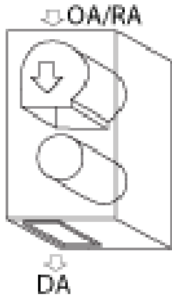

## Discharge Options

Horizontal Unit/Horizontal Discharge	Upright Unit/Top Left Discharge	Upright Unit/Bottom Left Discharge
		
Horizontal Unit/Bottom Discharge	Upright Unit/Top Right Discharge	Upright Unit/Bottom Right Discharge
		
Horizontal Unit/Top Discharge	Upright Unit/Top Discharge	Upright Unit/Bottom Discharge
		
LEGEND		
OA = Outside Air	DA = Discharge Air	RA= Return Air